

MITSUBISHI

三菱工業用ミシン部品カタログ

Industrial Sewing Machine Parts Catalog

Model LY2-3310

目次	CONTENTS	Page
	ミシン用部品コード採番基準	MITSUBISHI SPARE PARTS No. Designation system 1
(A) 本体関係	Arm bed & It's accessories	2
(B) 縫機構(Ⅰ)	Sewing mechanism (Ⅰ)	4
(C) 縫機構(Ⅱ)および下送り機構	Sewing mechanism (Ⅱ) & Feed rock lower shaft mechanism	6
(D) 送り調節機構	Stitch length mechanism	8
(E) 上部水平送り機構	Upper feed rock shaft mechanism	10
(F) 上部上下送り機構	Upper feed lifting rock shaft mechanism	12
(G) 押え機構	Presser foot mechanism	14
(H) 糸切り機構	Knife actuating mechanism	16
(J) タッチバック機構	Touch back mechanism & Deterctor mechanism	18
	および検出器機構	
(K) 給油機構	Oil lubrication mechanism	20
(L) 付属品	Accessories	22
(M) 索引	Index	24

A 本体機構
ARM BED & IT'S ACCESSORIES

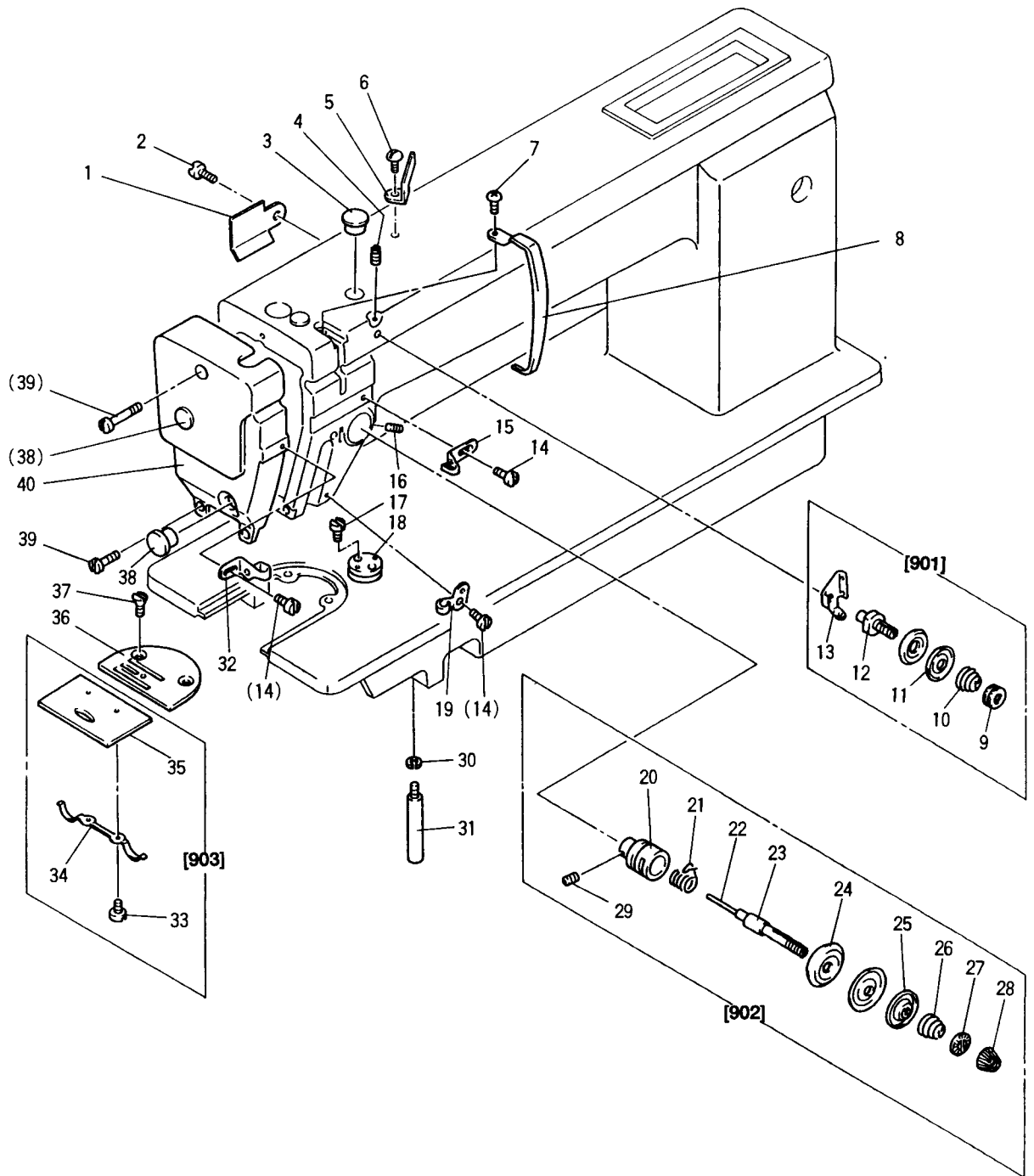

A 本体機構

ARM BED & IT'S ACCESSORIES

Fig. No.	変更 Mod	部品コード Parts.No.	部品名	Description	使用数 Amt. Reg.
A01		MG33A0873	油シールドプレート	Oil shield plate	1
A02		M91109004	サカネツキフライネジ	Screw 11/64(40)x8	1
A03		M91305080	セン	Rubber plug 13	1
A04		M91108001	トメネジ	Set screw 11/64(40)x5.5	1
A05		MF36A1180	イトアンナイ	Thread guide (arm top)	1
A06		M91116002	ヒラネジ	Screw 11/64(40)x8	1
A07		M91106004	フライネジ	Screw 11/64(40)x8	1
A08		MF03A0584	テビンカハ	Thread take-up cover	1
A09		M91101046	ツマミナット	Pre-tension adjusting nut 11/64(40)	1
A10		MF36A0245	エンストリハネ	Pre-tension spring	1
A11		MF10A1555	テウシガラ	Tension discs for pre-tension	2
A12		MF90A0553	テウシホウ	Pre-tension stud	1
A13		MF00A0181	イトアンナイ	Thread guide	1
A14		M90909003	マルヒラネジ	Screw 9/64(40)x6	3
A15		MG43A0181	イトアンナイ	Thread guide	1
A16		M91508001	トメネジ	Set screw 15/64(28)x6	1
A17		M91107002	ヒラネジ	Screw 11/64(40)x5.5	2
A18		MG30A0601	トリツケイタ	Cloth guide plate	1
A19		MQ50A0181	イトアンナイ	Thread guide	1
A20		MF10A0709	フツシユ	Thread tension regulator bushing	1
A21		MF02A0187	イトトリハネ	Thread take-up spring	1
A22		M90204060	ピン	Thread tension releasing pin ϕ 2x28.4	1
A23		MF02A0553	テウシホウ	Thread tension stud	1
A24		MF10A0555	テウシガラ	Thread tension discs	2
A25		MM11A0556	テウシガラオサエ	Thread tension releasing discs	1
A26		MG52A0245	エンストリハネ	Thread tension spring	1
A27		MT60A0802	マワリトメ	Thumb nut revolution stopper	1
A28		M91605045	ツマミナット	Thumb nut 1/4(40)	1
A29		M90901002	ヒラネジ	Screw 9/64(40)x4	1
A30		M90625053	ハネサカネ	Spring washer for leg 6	1
A31		MG33A0426	ササエ	Leg	1
A32		MG43A1181	イトアンナイ	Thread guide	1
A33		M90604002	ヒラネジ	Screw 3/32(56)x2.2	2
A34		MF10A0471	イタハネ	Spring for slide plate	1
A35		-	スベリイタ	Slide plate	1
A36		MF26B0101	ハリイタ	Needle plate (B2.6)	1
A37		M91102011	マルサラネジ	Screw 11/64(40)x8.5	2
A38		M91182080	セン	Rubber plug ϕ 11.8	2
A39		M91106003	マルヒラネジ	Screw 11/64(40)x20	3
A40		MG33A0830	メンイタ	Face plate	1
A901		MF00E0550	イトテウシキミタテ	Pre-tension assy.	1
A902		MG34E0210	テウシキミタテ	Thread tension regulator complete	1
A903		MF10E0470	スベリイタキミタテ	Slide plate complete	1

B 縫機構 (I)
SEWING MECHANISM (I)

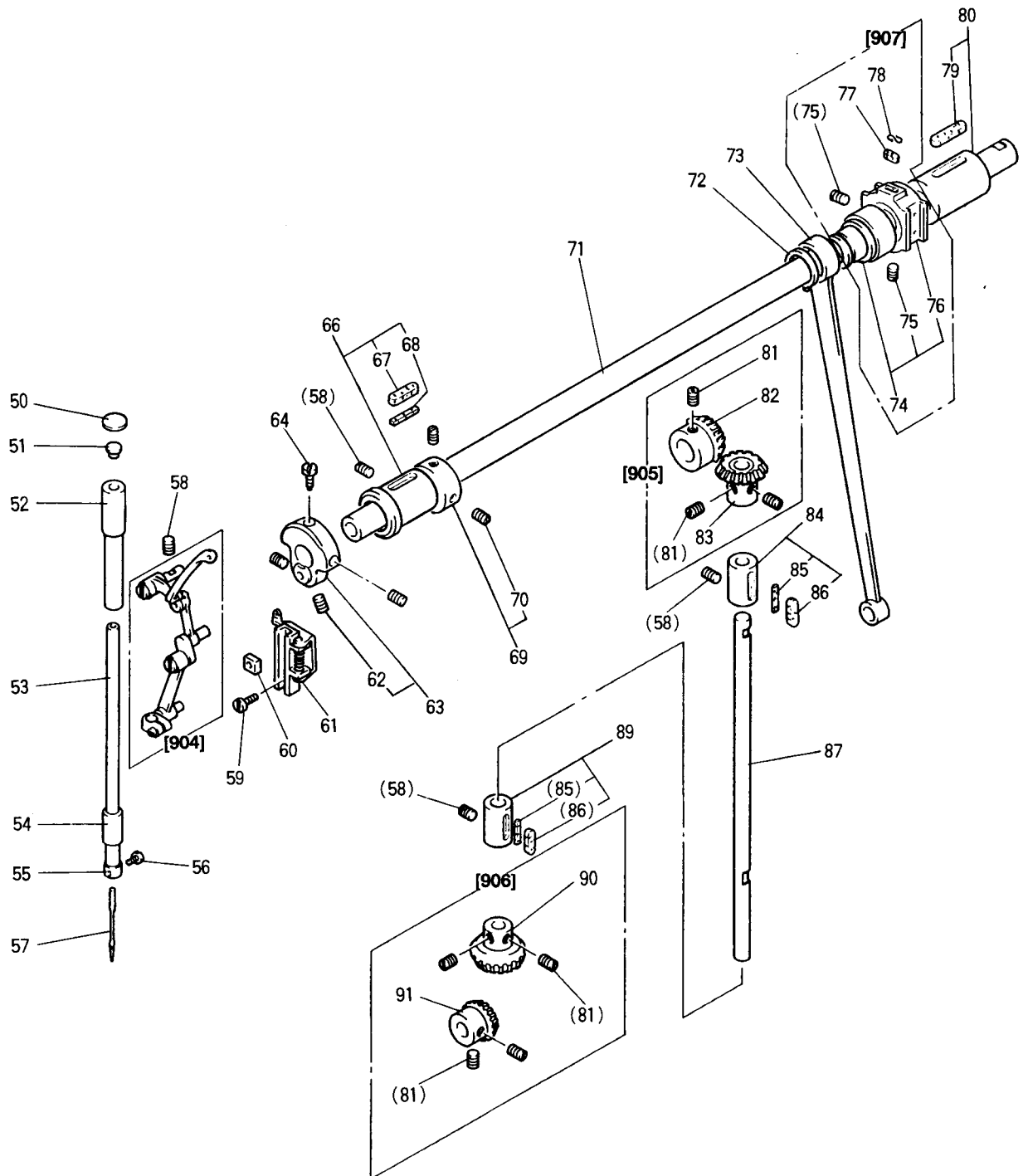

B 縫機構 (1)

SEWING MECHANISM (1)

Fig.	変更	部品コード	部品名	Description	使用数
No.	Mod	Parts.No.			Amt. Reg.
B50		MF60A0742	フタ	Cap for needle bar bushing(upper)	1
B51		MF10A2740	フェルト	Felt for needle bar bushing(upper)	1
B52		MF60A0663	ハリホウメタルウエ	Needle bar bushing(upper)	1
B53		MG50A0660	ハリホウ	Needle bar	1
B54		MF20A0664	ハリホウメタルシタ	Needle bar bushing(under)	1
B55		MG42A0181	イトアンナイ	Tread guide for needle bar	1
B56		M90815002	ヒラネジ	Screw 1/8(44)x4.5	1
B57		MG37A0128	ミシンハリ DPX17-22	Needle DPX17#22	1
B58		M91513001	トメネジ	Set screw 15/64(28)x10	4
B59		M91106004	フアラマイネジ	Screw 11/64(40)x8	2
B60		MF30A0325	カクコマ	Square block	1
B61		MG44E0662	ハリカイトクミタテ	Needle bar connecting link guide assy.	1
B62		M91606001	トメネジ	Set screw 1/4(40)x6	3
B63		MF60A1383	クランククミタテ	Crank assy.	1
B64		M91802006	ヒラネジホウサキ	Screw 9/32(28)x14	1
B66		MF60A0232	ウウシクメタルヒタリクミタテ	Bushing for arm shaft(left)	1
B67		MV88A0740	フェルト	Felt	1
B68		MG50A0740	フェルト	Felt	1
B69		MF80A0352	カラークミタテ	Collar for arm shaft assy.	1
B70		M91602001	トメネジ	Set screw 1/4(40)x4	2
B71		MG33A0230	ウウシク	Arm shaft	1
B72		M90320065	カトメウシクヨウ 20	C-type stop ling 20	1
B73		MG33A0384	レンセツカン	Crank rod assy.	1
B74		MF30E0280	ハンシンリンクミタテ	Upper feed lifting cam	1
B75		M91506001	トメネジ	Set screw 15/64(28)x7	2
B76		MG34A0325	カクコマ	Square block	1
B77		MF60A1740	フェルト	Felt	1
B78		MF60A0700	センサイクハネ	Spring for feed cam	1
B79		MF60A2740	フェルト	Felt	1
B80		MG33A0233	ウウシクメタルミキクミタテ	Bushing for arm shaft(right)	1
B81		M91610001	トメネジ	Set screw 1/4(40)x7	8
B82		MF40A0331	ウウシクカサハクノマ	Bevel gear for arm shaft	1
B83		MF40A0333	タテシクカサハクノマウエ	Bevel gear for vertical shaft(upper)	1
B84		MQ70A0521	タテシクメタルクミタテ	Vertical shaft bushing assy.	1
B85		MQ50A0148	ヒモ	Oil wick	2
B86		MF60A0740	フェルト	Felt	2
B87		MG50A0520	タテシク	Vertical shaft	1
B89		MF67B0522	タテシクメタルクミタテ	Vertical shaft bushing assy.	1
B90		MF10A0332	タテシクカサハクノマシタ	Bevel gear for vertical shaft(lower)	1
B91		MF40A0332	シタシクカサハクノマ	Bevel gear for hook shaft	1
B904		MG40E0580	テンヒンハリクミタテ	Thread take-up lever assy.	1
B905		MF01E0331	カサハクノマクミタテ	Bevel gear for arm shaft	1
B906		MF01E0332	カサハクノマクミタテ	Bevel gear for arm shaft	1
B907		MG33E0760	ハンシンリンクミタテ	Upper feed lifting cam	1

C
 縫機構（Ⅱ）および下送り機構
 SEWING MECHANISM（Ⅱ）& FEED ROCK LOWER SHAFT MECHANISM

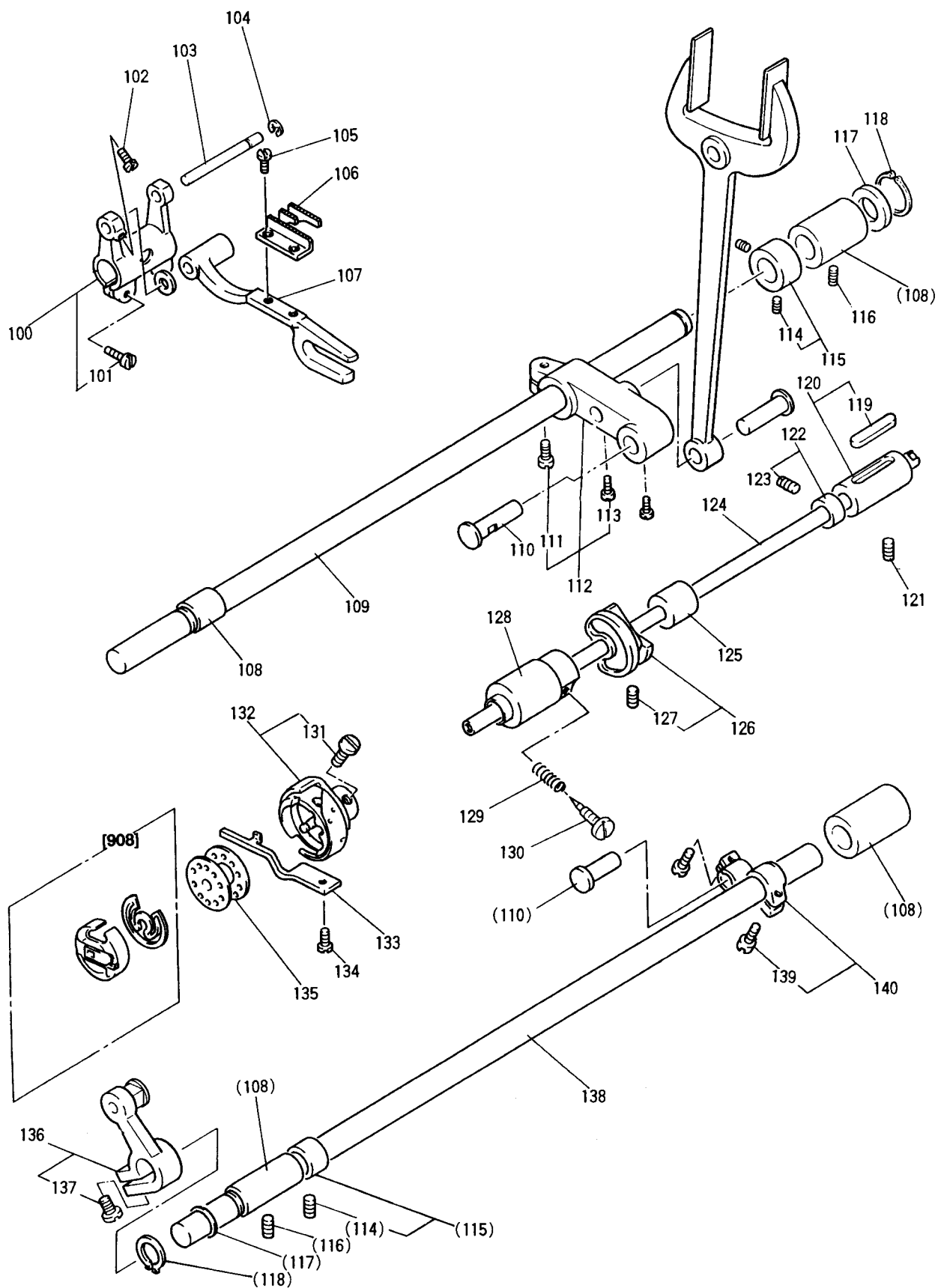

C 縫機構 (II) および下送り機構

SEWING MECHANISM (II) & FEED ROCK LOWER SHAFT MECHANISM

Fig. 変更	部品コード	部品名	Description	使用数	
No.	Mod	Parts.No.		Amt. Reg.	
				BT	
C100		MG30A0278	スライオクリウテヒタリクミタテ	Feed rock shaft crank(left)assy.	1
C101		M91203002	ヒラネジ	Screw 3/16(28)x15	2
C102		M91106004	フライネジ	Screw 11/64(40)x8	2
C103		MG33A0283	オクリタイザシク	Feed bar holder stud	1
C104		M70535065	Eカトメリ 5	E-type stop ring 5	1
C105		M90806002	ヒラネジ	Screw 1/8(44)x6	2
C106		MF10A0104	オクリ	Feed dog	1
C107		MG33A0281	オクリタイ	Feed bar	1
C108		MG33A0285	オクリシクメタル	Feed rock shaft bushing	4
C109		MG33A0284	オクリシク	Feed rock shaft	1
C110		M90904060	ピン	Pin	3
C111		M91603003	マルヒラネジ	Screw 1/4(24)x16	1
C112		MG30B0306	オクリクウテクミタテ	Feed lifting & rock shaft crank assy.	1
C113		M91516002	ヒラネジ	Screw 15/64(28)x8.5	2
C114		M91602001	トメネジ	Set screw 1/4(40)x4	4
C115		MF80A0352	カラクミタテ	Collar for arm shaft assy.	2
C116		M91513001	トメネジ	Set screw 15/64(28)x10	2
C117		M91502050	サカネ	Washer φ20.5	2
C118		M90315065	Cカトメリ シクヨウ 15	C-type stop ling 15	2
C119		MF60A0740	フェルト	Felt	1
C120		MG37B0452	シタシクメタルミキクミタテ	Rotating hook shaft bushing(right)assy.	1
C121		M91110001	トメネジ	Set screw 11/64(40)x8.5	1
C122		MF30A0352	カラクミタテ	Thrust collar	1
C123		M91503001	トメネジ	Set screw 15/64(28)x4.5	2
C124		MG52A0450	シタシク	Rotating hook shaft	1
C125		MF00A0453	シタシクメタルナカ	Lower shaft bushing(middle)	1
C126		MF00A0350	イトキリカムクミタテ	Thread trimmer cam assy.	1
C127		M91602020	ロツカアナツキトメネジ	Soket set screw 1/4(40)x10	2
C128		MG50A0451	シタシクメタルヒタリクミタテ	Rotating hook shaft bushing(left)	1
C129		MG30A0700	ツルマキハネ	Spring	1
C130		M90801006	ヒラネジホウサキ	Screw M3x0.35x9.5	1
C132		MG44B0120	カマクミタテ KHS20-RMP	Rotating hook compleate KHS20-RMP	1
C133		MF20A0229	ウチカマトメ	Rotating hook positioner	1
C134		M91118002	ヒラネジ	Screw 11/64(40)x10	1
C135		MF25B0123	ホピン	Bobbin	1
C136		MF70E0276	シヨウカオクリウテヒタリクミタテ	Feed lifting rock shaft crank(left)assy.	1
C137		M91112002	ヒラネジ	Screw 11/64(40)x12	1
C138		MG33A1284	オクリシク	Feed lifting rock shaft	1
C139		M91204003	マルヒラネジ	Screw 3/16(28)x12	2
C140		MF70A0277	シヨウカオクリウテミキクミタテ	Feed lifting rock shaft crank(right)assy.	1
C908		MG44E0125	ホピンケース	Bobbin case compleate	1

D 送り調節機構
STITCH LENGTH MECHANISM

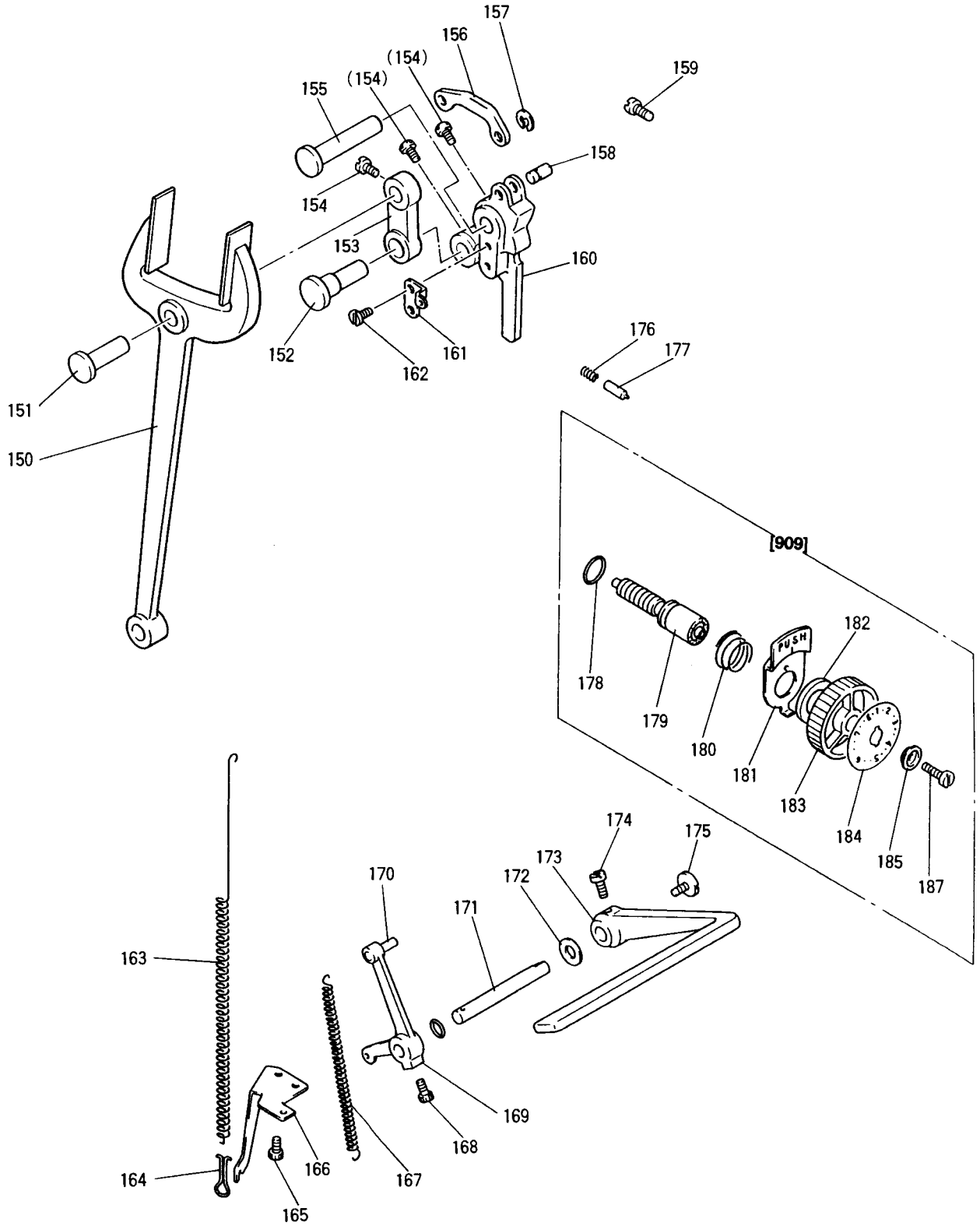

D 送り調節機構

STITCH LENGTH MECHANISM

Fig. 変更 部品コード		部品名	Description	使用数	
No.	Mod			Parts.No.	Amt. Reg.
				1 8	
D150		MF65B0744	フタマダロッド	Feed forked connecting rod	1
D151		M90720063	タンスキシク	Set pin	1
D152		MG33A0761	ハンシシク	Eccentric pin	1
D153		MG33A0910	リンク	Link	1
D154		M91516002	ヒラネジ	Screw 15/64(28)x8.5	3
D155		MG33A0530	タンスキシク	Set pin	1
D156		MF00A1910	リンク	Link	1
D157		M70534065	Eタイプメリ 4	E-type stop ring 4	1
D158		M90534060	ピン	Pin ϕ 5.5	1
D159		M91502002	ヒラネジ	Set screw 15/64(28)x12	1
D160		MG34A0291	オクリチヨウセツカム	Feed regulator	1
D161		MF40A2708	カカネ	Spring holder	1
D162		M91110002	ヒラネジ	Screw 11/64(40)x8	2
D163		MG50A0572	ツルマキハネ	Spring	1
D164		MN15A0708	カカネ	Spring holder	1
D165		M91106004	フアラメネジ	Screw 11/64(40)x8	2
D166		MG34A0708	ハネカケイタ	Spring holder	1
D167		MF10A0572	ツルマキハネ	Spring	1
D168		M91501007	マルヒラネジホウサキ	Screw 15/64(28)x14.5	1
D169		MF60A0634	ヌイメカケンウテ	Stitch length regulator	1
D170		MG34A0530	タンスキシク	Set pin	1
D171		MF60A0633	ヌイメカケンシク	Reverse stitch lever shaft	1
D172		M95003053	ハネサカネ	Spring washer	1
D173		MF30A0632	ヌイメカケンレバ	Reverse swing lever	1
D174		M91515002	ヒラネジ	Screw 15/64(28)x10	2
D175		M91207003	マルヒラネジ	Screw 3/16(28)x6.5	1
D176		MF05A0572	ツルマキハネ	Spring	1
D177		MF00A0852	ピン	Stopper pin	1
D178		M91000085	Oリング 1AP10A	O-ring ϕ 10 1AP10A	1
D179		MF85A0640	オクリチヨウセツネジ	Stitch length regulator screw	1
D180		MF02A0245	エンスイハネ	Coil spring	1
D181		MF06A0950	レバ	Releasing lever	1
D182		MF06A0417	ゴムワ	Rubber ring	1
D183		MF06A0631	ダイヤル	Dial for stitch length regulator	1
D184		MG75A0841	メモリイタ	Stitch length indicating plate	1
D185		MF00A0257	オサエカネ	Bushing	1
D187		M71216002	ヒラネジ	Screw 3/16(28)x18	1
D909		MG34E0640	オクリチヨウセツネジクミタテ	Screw bar assy.	1

E 上部水平送り機構
UPPER FEED ROCK SHAFT MECHANISM

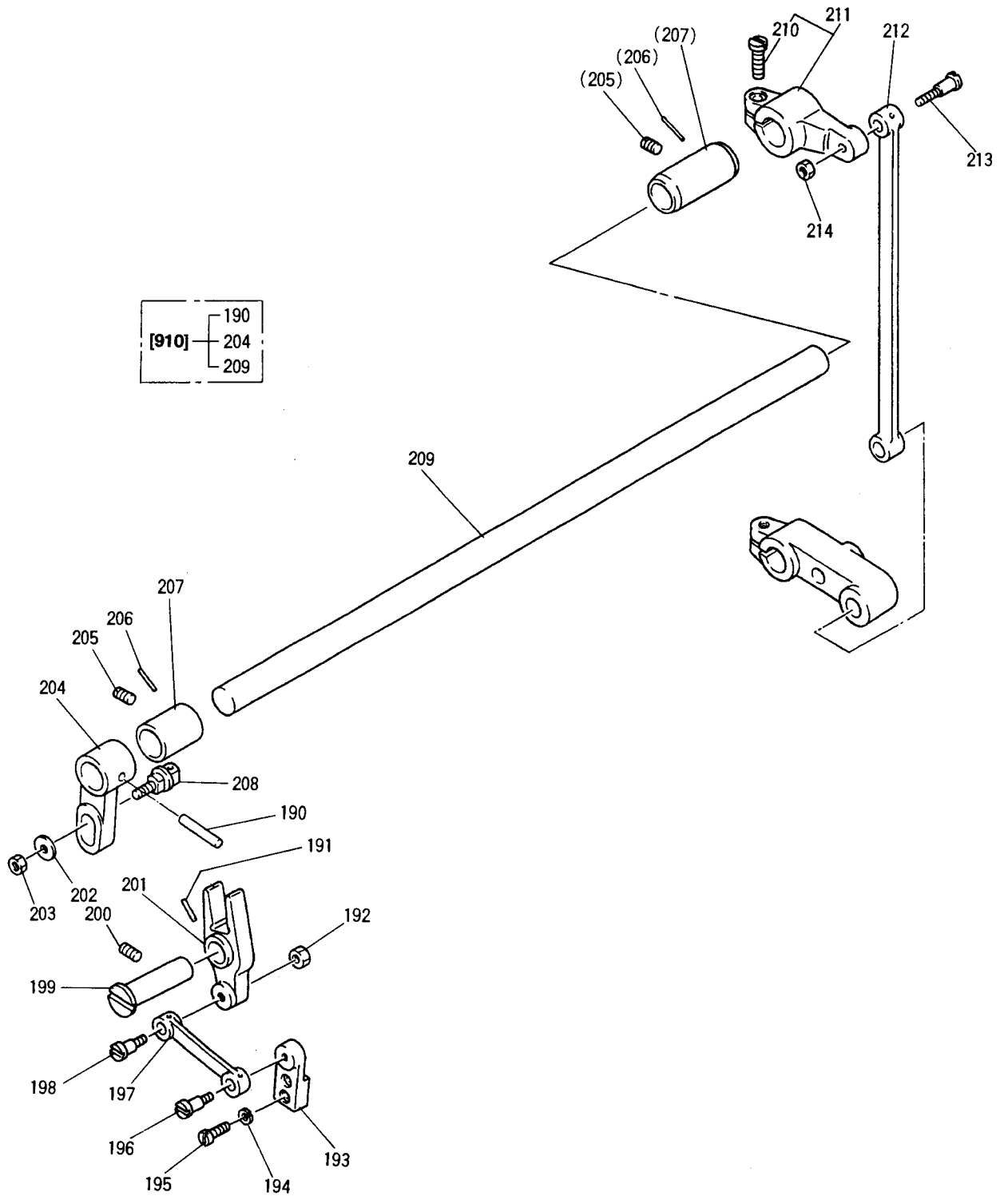

E 上部水平送り機構

UPPER FEED ROCK SHAFT MECHANISM

Fig. 変更		部品コード		部品名	Description	使用数
No.	Mod	Parts.No.				Amt. Reg.
						1 B
E190		M90401061		テーパピン	Taper pin	1
E191		MV88A0740		フェルト	Felt	1
E192		M91620045		ナット	Nut 1/4(40)	1
E193		MG33A0602		トリツカガネ	Feed arm	1
E194		M90304053		ハネサガネ 3.5	Spring washer 3.5	2
E195		M90910003		マルヒラネジ	Screw 9/64(40)x7	2
E196		M91615015		ヒラネジ タンツキ	Hinged screw 1/4(40)x12	1
E197		MG33A1956		レンセツカン	Walking foot connecting link	1
E198		M91683015		ヒラネジ タンツキ	Hinged screw 1/4(40)x25	1
E199		MG30A0530		タンツキシク	Hinged pin	1
E200		M91506001		トメネジ	Set screw 15/64(28)x7	1
E201		MG33A0950		ハンカンレバ	Feed connecting lever	1
E202		M90601050		ミカキサガネ 6	Washer 6	1
E203		M91604045		ナット	Nut 1/4(24)	1
E204		MG30B0464		シヨウフスハイウテヒタリ	Feed griving rock shaft crank(left)	1
E205		M91108001		トメネジ	Set screw 11/64(40)x5.5	2
E206		MG50A1740		フェルト	Felt	2
E207		MG33A1285		オクリシクメタル	Feed driving shaft bushing	2
E208		MG30E0410		コロサエシククミタテ	Feed connecting slick block complete	1
E209		MG30B0467		シヨウフスハイウテシク	Feed driving shaft (upper)	1
E210		M91603003		マルヒラネジ	Screw 1/4(24)x16	1
E211		MG30E0465		シヨウフスハイウテミキクミタテ	Feed driving rock shaft crank (right)assy.	1
E212		MG30B0954		レンセツカン	Feed driving connecting link	1
E213		M91803015		ヒラネジ タンツキ	Hinged screw 9/32(28)x26.1	1
E214		M91802045		ナット	Nut 9/32(28)	1
E910		MG30E0467		シヨウフスハイオクリシククミタテ	Feed driving shaft complete	1

F 上部上下送り機構
UPPER FEED LIFTING ROCK SHAFT MECHANISM

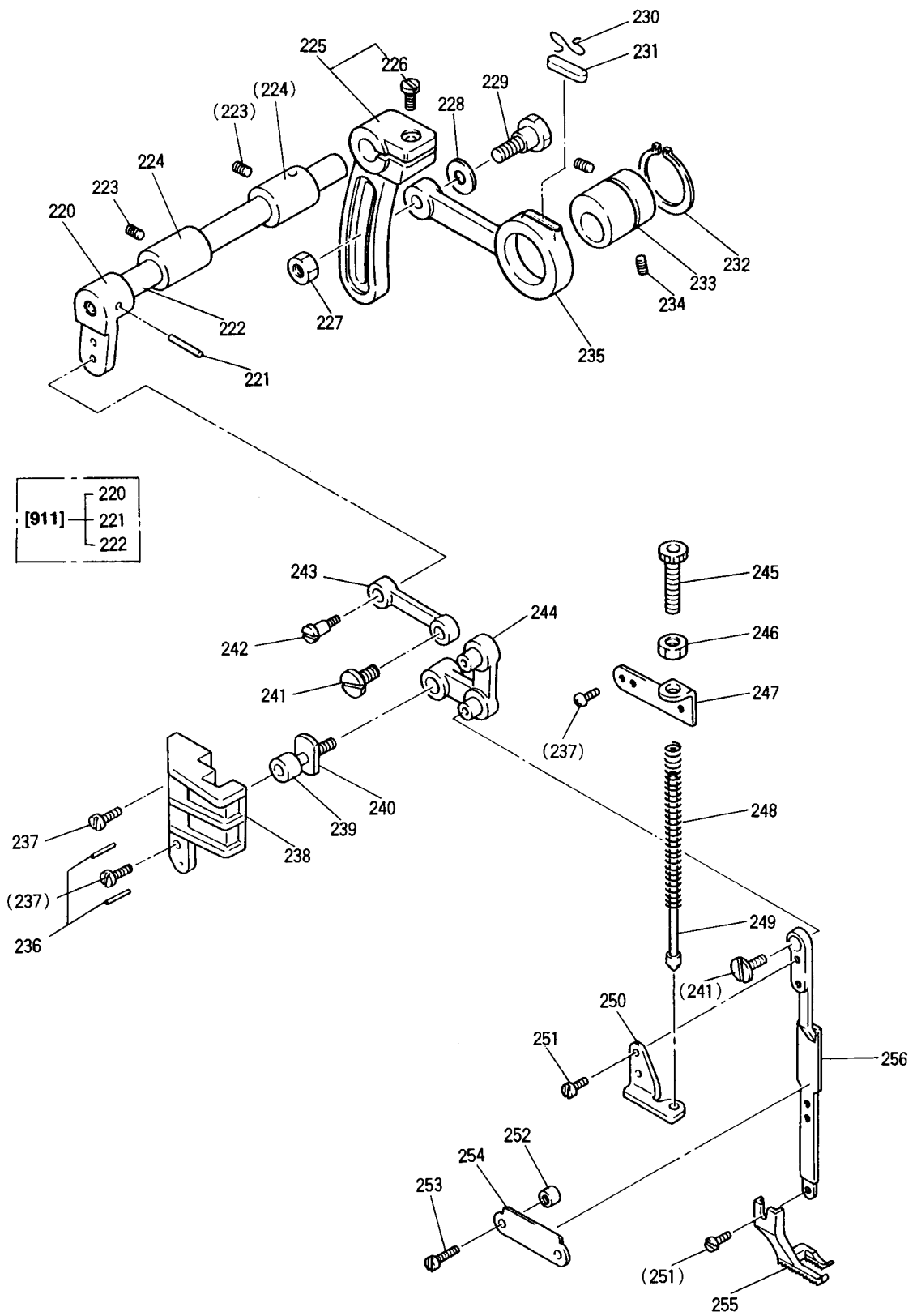

F 上部上下送り機構

UPPER FEED LIFTING ROCK SHAFT MECHANISM

Fig.	変更	部品コード	部品名	Description	使用数
No.	Mod	Parts.No.			Amt. Reg.
					BIT
F220		MG33A0462	シヨウフシヨウケウテヒタリ	Upper feed lifting rock shaft crank	1
F221		M90207061	テハヒン 4X20	Taper pin 4X20	1
F222		MG30A0460	シヨウフシヨウケシク	Feed lifting rock shaft	1
F223		M91108001	トメネシ	Set screw 11/64(40)X5.5	2
F224		MG33A0833	シヨウフシヨウケメタル	Feed lifting rock shaft bushing	2
F225		MG30A0463	シヨウフシヨウケウテミキクミタテ	Feed lifting rock shaft crank(right)assy.	1
F226		M91603003	マルヒラネシ	Screw 1/4(24)X16	1
F227		M91572045	Uナット 6X0.75	U-nut 6x0.75	1
F228		M90601050	ミカキザカネ 6	Washer 6	1
F229		M91551015	トクシホルト	Hinged screw M6X24	1
F230		MF60A0700	センサイカハネ	Spring for felt stopper	1
F231		MG30B0740	フェルト	Felt	1
F232		M90325065	C外トメワシクヨウ 25	C-type stop ring 25	1
F233		MG30A0760	ハンシンリン	Feed lifting eccentric	1
F234		M91606001	トメネシ	Set screw 1/4(40)x6	2
F235		MG33A0956	レンセツカン	Feed connecting crank rod	1
F236		M90301064	スプリングヒン 3X8	Spring pin 3X8	2
F237		M91106004	フライネシ	Screw 11/64(40)X8	4
F238		MG33A0765	ベルクランクガイド	Bell crank guide bracket	1
F239		MG10B0411	ブロック	Bell crank guide bracket block	1
F240		M90507063	サヤシク	Bell crank guide pin	1
F241		M91210002	ヒラネシ	Screw 3/16(28)X10	2
F242		M91681015	ヒラネシタメツキ	Hinged screw 1/4(40)X12	1
F243		MG10B0910	レンセツカン	Feed lifting rock shaft link	1
F244		MG10B0763	ベルクランク	Bell crank	1
F245		M91801035	ツマミネシ	Feed regulating screw 9/32(28)X31	1
F246		M91802045	ナット	Nut 9/32(28)	1
F247		MG33A0261	オサエチヨウセツタイ	Presser regulating bracket	1
F248		MG33A0572	ツルマキハネ	Spring	1
F249		MG33A0154	アンナイカネクミタテ	Spring guide bar complete	1
F250		MG33A1361	ハネカケカネ	Spring holder	1
F251		M90922002	ヒラネシ	Screw 9/64(40)X8	3
F252		M93009050	ザカネ	Washer	2
F253		M91112002	ヒラネシ	Screw 11/64(40)X12	2
F254		MG30A0296	ソトオサエアンナイ	Walking foot guide bracket	1
F255		MG10B0294	ソトオサエ	Walking foot	1
F256		MG33A0295	オクリアシサエ	Walking foot guide link	1
F911		MG33E0460	ウテクミタテ	Feed lifting rock shaft complete	1

G 押え機構
PRESSER FOOT MECHANISM

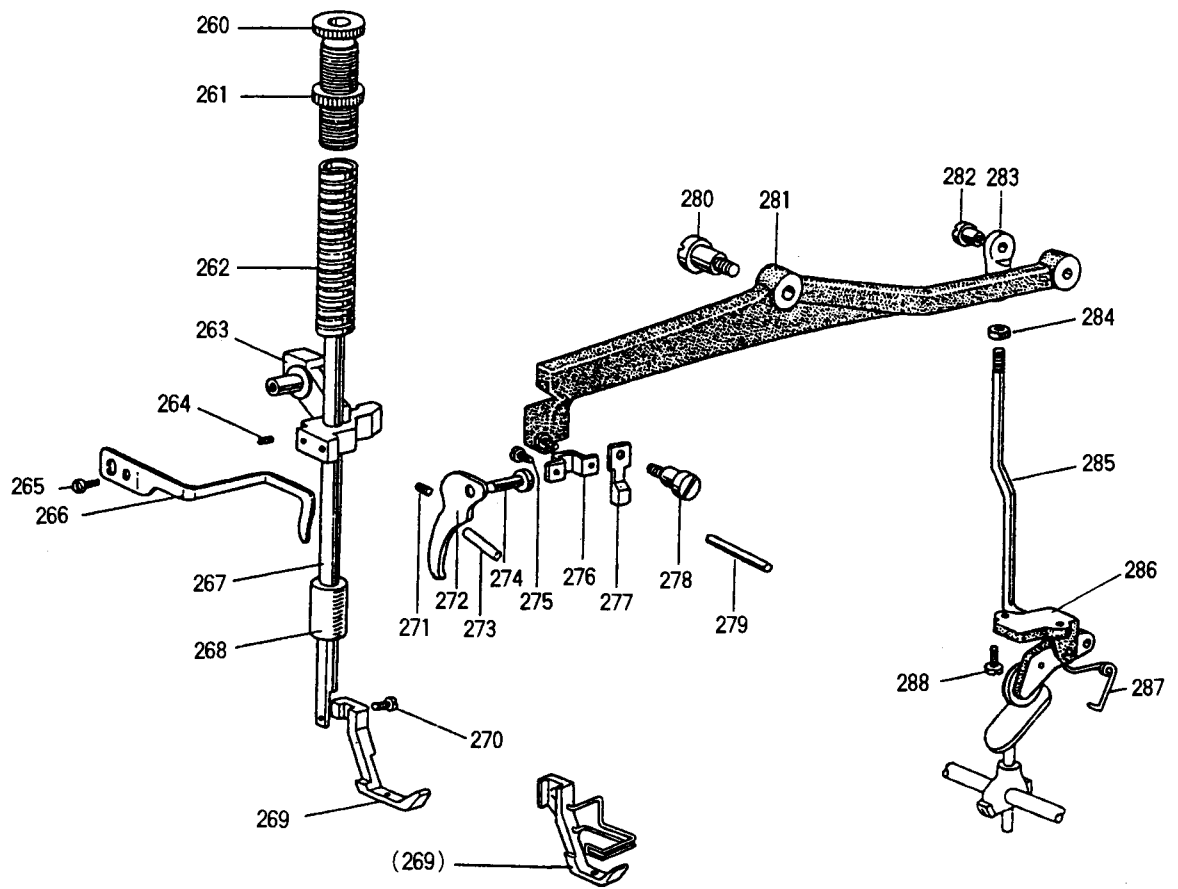

G 押え機構

PRESSER FOOT MECHANISM

Fig. 変更		部品コード	部品名	Description	使用数
No.	Mod	Parts.No.			Amt. Reg.
					BIT
G260		M93223035	ツマミネジ	Thumb screw 1/2(28)x43	1
G261		M93202047	トクシユナツト	Nut	1
G262		MV01A0259	ツルマキハネ	Presser bar spring	1
G263		MG10B0265	オサエホウタキ	Presser bar holder	1
G264		M91506001	トメネジ	Set screw 15/64(28)x7	1
G265		M91109002	ヒラネジ	Screw 11/64(40)x7	1
G266		MN30A0216	ウワイトアンナイ	Thread guide	1
G267		MF60A0262	オサエホウ	Presser bar	1
G268		MF10A0267	オサエホウメタル	Presser bar busing	1
G269		MG41B0256	ウチオサエ	Presser foot (inside)	1
G269		MG52E0256	ウチオサエクミタテ	Presser foot (inside)assy.	(1)
G270		M90922002	ヒラネジ	Screw 9/64(40)x8	1
G271		M91110001	トメネジ	Set screw 11/64(40)x8.5	1
G272		MF60A0252	オサエアケ	Presser foot lifter	1
G273		M90402064	スプリングピン 3X18	Spring pin 3x18	1
G274		M90704063	タツキピン	Presser foot lifting pin	1
G275		M91106004	フライネジ	Screw 11/64(40)x8	2
G276		MG30A0154	アンナイカネ	Guide plate	1
G277		MG33A0221	イトユルメ	Upper thrad releasing cam	1
G278		M91223015	ヒラネジ タツキ	Hinged screw 3/16(28)x6.2	1
G279		M90421060	イトユルメピン	Upper thrad releasing pin	1
G280		M92001016	マルヒラネジ タツキ	Hinged screw 5/16(24)x30	1
G281		MG51A0725	ヒサアケレバ	Lifting lever	1
G282		M91505016	マルヒラネジ タツキ	Hinged screw 15/64(28)x10	1
G283		MG33A0571	ツキテ	Knee lifting rock shaft arm	1
G284		M91251045	ナツト	Nut 3/16(32)	1
G285		MG30B0593	ソウサホウ	Knee lifter lever connecting rod	1
G286		MG30E1594	ヒサアケレバシタクミタテ	Knee lifter bell crank assy.	1
G287		MG33A0729	ヒネリハネ	Knee lifter ball crank spring	1
G288		M91104003	マルヒラネジ	Screw 11/64(40)x12	2

H 糸切り機構
KNIFE ACTUATING MECHANISM

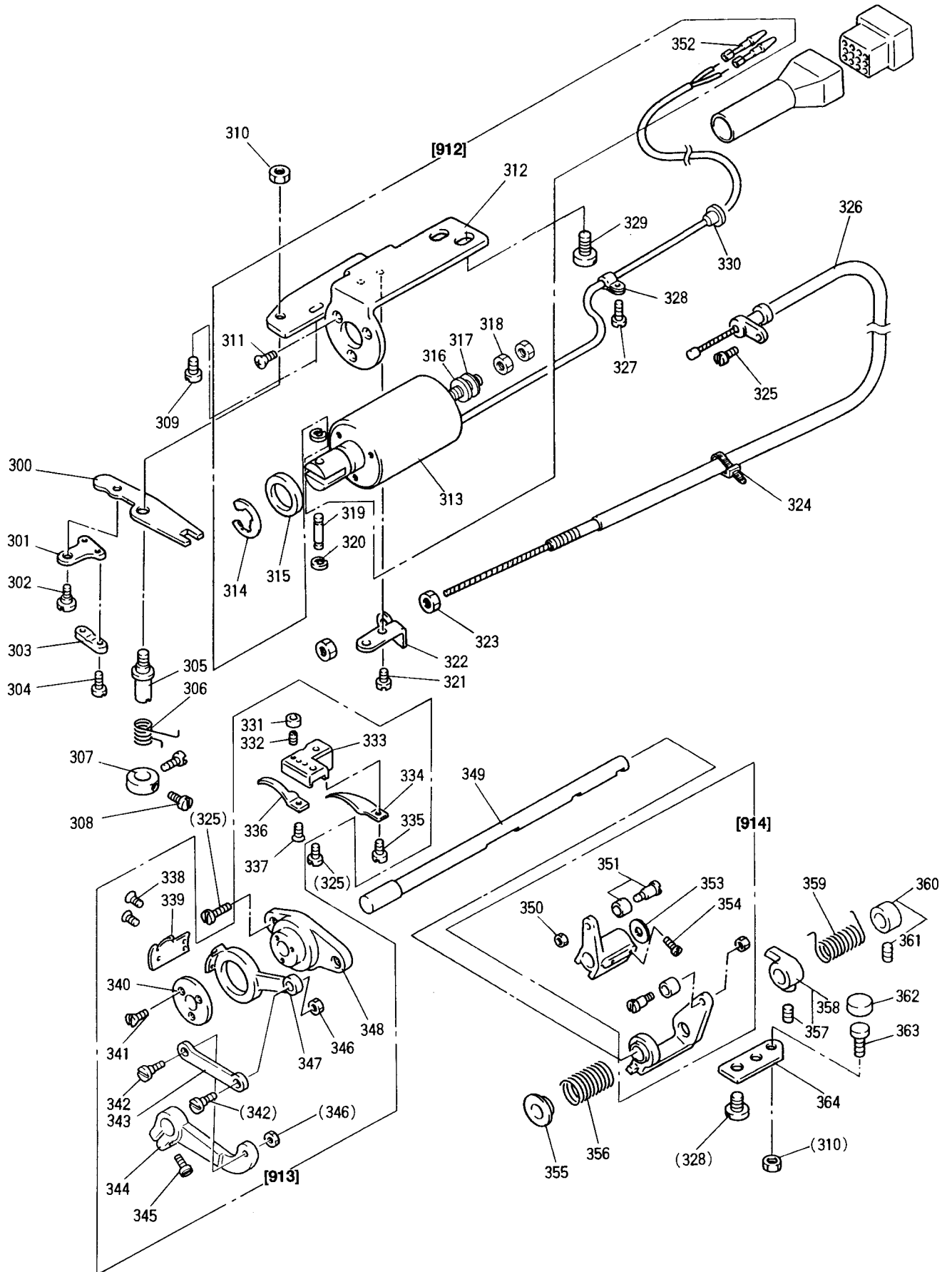

H 系切り機構
KNIFE ACTUATING MECHANISM

Fig. 変更 部品コード			部 品 名	Description	Amt. Reg.
No.	Mod	Parts.No.			使用数
H300		MF00A1391	クトウイテ	Thread trimmer driving lever	1
H301		MF06A1361	カカネ	Flexible wire holder	1
H302		M71144015	ヒラネジ*タ*ンツキ	Stud screw 11/64(40)x5	1
H303		MF36A0750	フ*ツシユ	Flexible wire presser	1
H304		M90802002	ヒラネジ	Screw 1/8(44)x7	2
H305		M97082030	トクシユネジ	Stud screw 15/64(28)x7.5	1
H306		MF00A1729	ヒネリハネ	Trimming lever spring	1
H307		MF00A1352	カラ	Spring support collar	1
H308		M90903002	ヒラネジ	Screw 9/64(40)x6.5	2
H309		M91118002	ヒラネジ	Screw 11/64(40)x10	1
H310		M91502045	ナツト	Nut 15/64(28)	2
H311		M94008037	P*ラネジ*M4x6	Screw M4x6	3
H312		MF00A1509	ソレノイト*トリツケイテ	Solenoid bracket	1
H313		-	ソレノイト	Solenoid	1
H314		M90703065	E*タメワ 12	E-type stop ring 12	1
H315		MF01A0397	クッション	Cushion	1
H316		MF06A0397	クッション	Cushion	1
H317		M70516050	サ*カ*ネ	Washer	1
H318		M92074075	ナツト M5	Nut M5	2
H319		M70428060	ヒ*ン	Link stud	1
H320		M70534065	E*タメワ 4	E-type stop ring 4	2
H321		M91106004	フ*ラマイネジ	Screw 11/64(40)x8	2
H322		MF06A0780	ホルダ	Holder	1
H323		M91373045	ナツト M5	Nut M5x4T	2
H324		MF06A1620	コテイヨウハ*ント SKB-1M	Band SKB-1M	1
H325		M91111004	フ*ラマイネジ	Screw 11/64(40)x10	4
H326		MF01E0746	フレキシブルワイヤクミタテ	Flexible wire assy.	1
H327		M91109004	サ*カ*ネツキ*フ*ラマイネジ	Screw 11/64(40)x8	1
H328		M94003099	ナイロンクリップ HP-3N	Cord holder	1
H329		M91510002	ヒラネジ	Screw 15/64(28)x12	4
H330		M91004080	ゴムフ*ツシユ	Rubber plug φ10	1
H331		M91110045	ナツト	Nut 9/64(40)	1
H332		M90913001	トメネジ	Set screw 9/64(40)x8.5	1
H333		MF00A1603	トリツケイテ	Bracket for fixed blade	1
H334		MF00A0180	イトアンナイ	Thread finger	1
H335		M90921002	ヒラネジ	Screw 9/64(40)x8	1
H336		MG52A0838	コテイメス	Fixed blade	1
H337		M91102010	サ*ラネジ	Screw 9/64(40)x4.1	1
H338		M91151010	サ*ラネジ	Screw 11/64(40)x7	2
H339		MG52A0834	メスヒタ*リ	Movable knife (left)	1
H340		M94006052	サ*カ*ネ	Thrust collar φ28	1
H341		M90803010	サ*ラネジ	Screw 1/8(44)x6	3
H342		M91111015	ヒラネジ*タ*ンツキ	Stud screw 11/64(40)x6.2	2
H343		MF00A8910	リンク	Link	1
H344		MF00A1392	クトウイテ	Knife driving crank	1
H345		M91117002	マルヒラネジ	Screw 11/64(40)x13	1
H346		M91107045	ナツト	Nut 11/64(40)	2
H347		MF02A0836	メスタ*ヒタ*リ	Knife base (left)	1
H348		MF00A1527	タ*イサ	Knife holding bracket saddle	1
H349		MF00A5454	メスヨウ*ウシ*ク	Knife driving shaft	1
H350		M91201045	ナツト	Nut 3/16(28)	2
H351		MF01E0411	コロ, コシ*クミタテ	Cam follower, Shoulder screw assy.	2
H352		M93003099	ヒ*ンターミナル(オス)	Terminal pin(Male)	2
H353		M71018050	サ*カ*ネ	Rubber washer	1
H354		M91516002	ヒラネジ	Screw 15/64(28)x8.5	2
H355		MF00A0750	フ*ツシユ	Bushing	1
H356		MF00A9572	ツルマキハネ	Coil spring	1
H357		M91606001	トメネジ	Set screw 1/4(40)x6	1
H358		MF06A0477	ストップ*クミタテ	Stopper lever assy.	1
H359		MF00A0729	ヒネリハネ	Coil spring	1
H360		M91602001	トメネジ	Set screw 1/4(40)x4	1
H361		MF01E1352	カラ*クミタテ	Thrust collar assy.	1
H362		MF06A1410	ストップ*ゴム	Stopper rubber	1
H363		M71510030	ストップ*ネジ	Stopper screw	1
H364		MF00A1477	ストップ*イテ	Lever stopper plate	1
H365		M90401085	O リング 1AP4	O-ring(1AP4)	1
H912		MF06E3519	ソレノイト*トリツケイテクミタテ	Thread trimming solenoid	1
H913		MF06E0839	メスタ*トリツケイテクミタテ	Knife blaket assy.	1
H914		MG34E0351	カムツシユウイテクミタテ	Cam follower crank assy.	1

J タッチバック機構および検出器機構
TOUCH BACK MECHANISM & DETECTOR MECHANISM

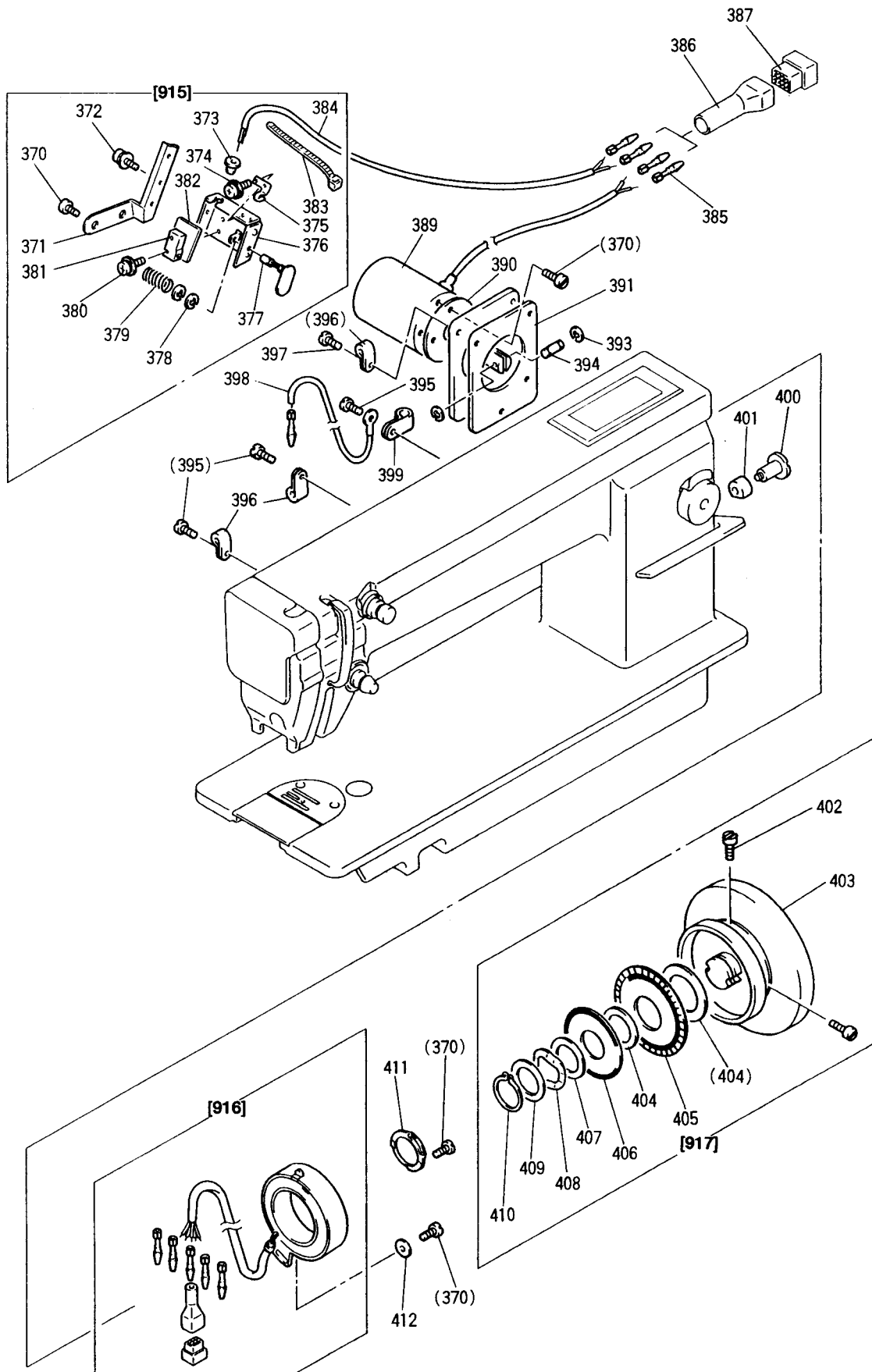

J タッチバック機構および検出器機構
TOUCH BACK MECHANISM & DETECTOR MECHANISM

Fig. 変更	部品コード	部品名	Description	使用数 Amt. Reg.	
No.	Mod	Parts.No.		1 8	
J370		M91106004	フ ^ラ マイネジ	Screw 11/64(40)x8	9
J371		MG34A0601	トリツケイタ 1	Plate	1
J372		M90309037	SW-PWツキ Pナ ^ハ ネジ	Screw M3X5	2
J373		M91004080	ゴムフ ^ラ ツシ	Rubber plug φ10	1
J374		M90201037	Pナ ^ハ ネジ	Screw 2X4	2
J374		M90315050	コサ ^カ ネM2	Washer M2	2
J374		M90306053	ハ ^ナ ネガ ^ネ M2	Washer M2	2
J375		MF00A0192	イタハ ^ネ	Plate spring	1
J376		MG75A1601	スイッチトリツケイタ	Bracket for touch switch	1
J377		MF00A0270	押し ^タ ン	Push button	1
J378		M70533065	E ^カ タメリ 3	E-type stop ring 3	2
J379		MF00A7572	ツルマキハ ^ネ	Coil spring	1
J380		M90251037	Pハ ^イ ント ^ネ ジ	Screw M2X8	2
J381		M90208099	マイクロスイッチ	Micro switch	1
J382		MF01A0502	セ ^ツ エンイタ	Insulator seat	1
J383		MF06A0620	コテヨウハ ^{ント}	Band	1
J384		M97033099	コ ^ト クミタテ	Cord assy.	1
J385		M93303099	ヒ ^ン 1380TL	Terminal pin	4
J386		MF06E0366	コネクタ ^キ ャップ ^ク ミタテ	Connector cap assy.	1
J387		M91018099	コネクタ-1360P	Nylon connector 12-pole	1
J389		MG34E0519	ソレノイ ^ド	Solenoid	1
J390		MF01A0691	カ ^ス ケット	Gasket	1
J391		MG34A0880	ヨコフ ^タ	Arm side cover	1
J393		M70534065	E ^カ タメリ 4	E-type stop ring 4	2
J394		M70428060	ヒ ^ン	Link stud	1
J395		M91109004	サ ^カ ネツキフ ^ラ マイネジ	Screw 11/64(40)X8	6
J396		M94003099	ナイロンクリップ ^{HP-3N}	Cord holder	3
J397		M91111004	フ ^ラ マイネジ	Screw 11/64(40)X10	1
J398		M97003095	ア ^ス センクミタテ	Ground wire assy.	1
J399		M94008099	ナイロンクリップ ^{HP-8N}	Cord holder	1
J400		M91515015	ヒラネジ ^タ ンツキ	Hinged screw	1
J401		MN36A0417	ゴム ^ワ	Rubber cushion	1
J402		M91502002	ヒラネジ	Set screw 15/64(28)X12	2
J403		MG34A0682	プ ^リ	Pulley	1
J404		MF01A0476	ス ^パ ーサ A	Spacer A	2
J405		MF01A2694	ハンジャハ ^ン B12	Speed command disc B12(down)	1
J406		MF01A1694	ハンジャハ ^ン B21	Speed command disc B21(up)	1
J407		MF01A1476	ス ^パ ーサ B	Spacer B	1
J408		MF01A0259	ハンテナイタオサエス ^フ リンク	Supporter spring	1
J409		M93001050	サ ^カ ネ	Washer 30	1
J410		M90330065	C ^カ タメリ	Retaining ring-C type 30	1
J411		MF01A0257	オサエ ^イ タ	Detector bracket supporter	1
J412		M93002050	サ ^カ ネ	Washer 12	1
J915		MG34E0534	タッチスイッチクミタテ	Touch switch assy.	1
J916		MB60A2406	ケンジツキクミタテ(センサ ^ー)	Detector bracket assy.(sensor)	1
J917		MG34E0682	プ ^リ クミタテ	Pulley assy.	1

K 給油機構
OIL LUBRICATION MECHANISM

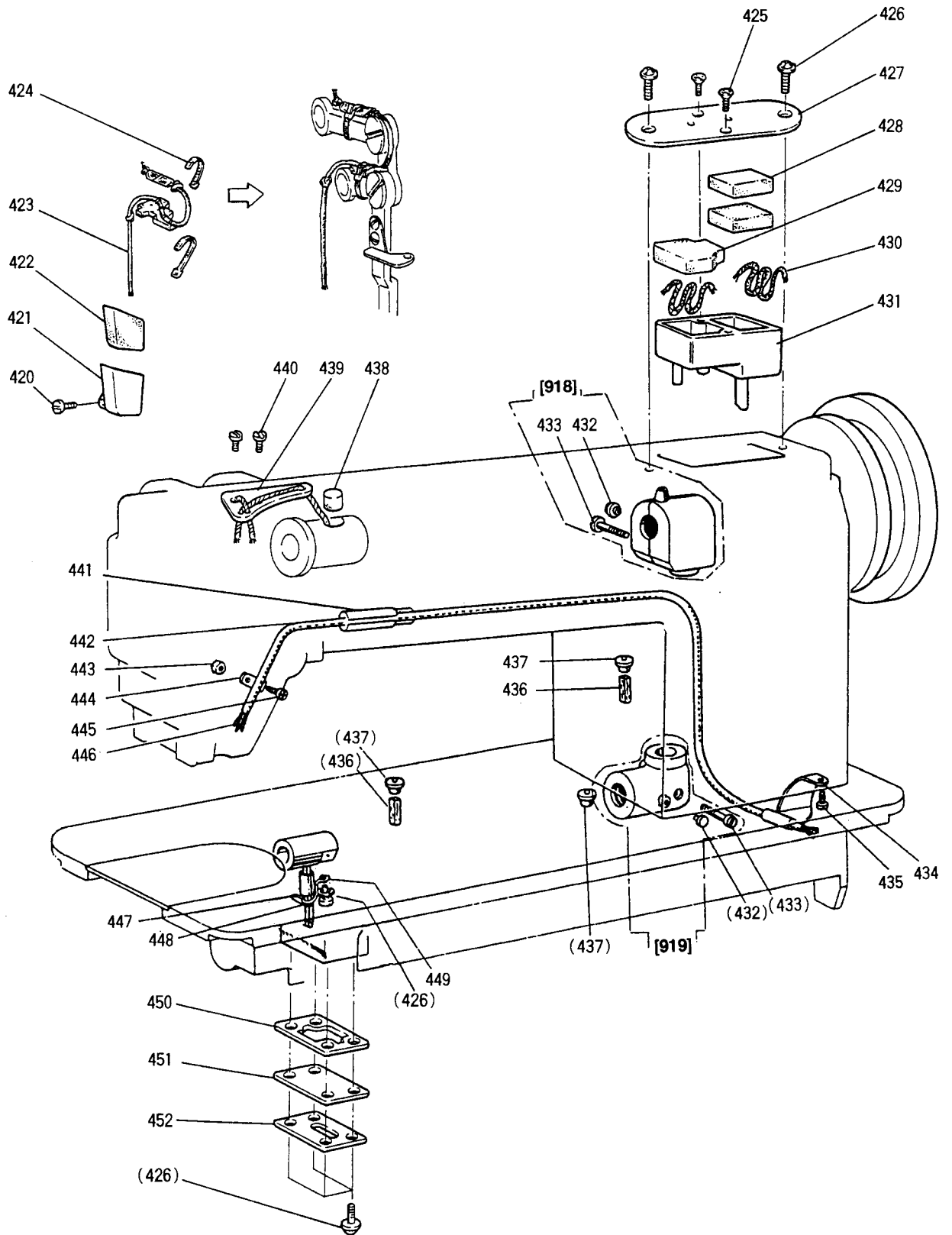

K 給油機構

OIL LUBRICATION MECHANISM

Fig. 変更	部品コード	部品名	Description	使用数 Amt. Reg.	
No.	Mod	Parts.No.		1 8	
K420		MG90908003	マルヒラネジ	Screw 9/64(40)x6	1
K421		MG33A0138	オイルタンク	Oil reservoir	1
K422		MG33A0740	フェルト	Felt	1
K423		MG33E0688	パイプヒモミキ	Oil pipe & wick complete	1
K424		MF06A1620	コテヨウバンド	Band SKB-1M	2
K425		MG90357037	ワッシャー	Screw 3x8	2
K426		MG91109004	パイプネジ	Screw 11/64(40)x8	7
K427		MG33A0134	パイプキャップ	Cap for oiler(right)	1
K428		MG33A1740	フェルト	Felt	2
K429		MG33A2740	フェルト	Felt	1
K430		MF10E3148	ヒモ	Oil wick	2
K431		MG33A1138	オイルタンク	Oil reservoir(right)	1
K432		MG90573080	ゴム	Rubber plug ϕ 5.7	2
K433		MG90531037	パイプネジ	Screw M5x14	2
K434		MG33A0780	パイプホルダ	Oil pipe holder	1
K435		MG91106004	パイプネジ	Screw 11/64(40)x8	1
K436		MG30A0740	フェルト	Felt	2
K437		MN10A4742	パイプキャップ	Cap for oiler	3
K438		MF10A2740	フェルト	Felt	1
K439		MG33E0601	パイプヒモミキ	Oil braid fitting plate	1
K440		MG90939002	パイプネジ	Screw 9/64(40)x11	2
K441		MG50A0688	パイプ	Oil pipe	1
K442		MG42A3731	パイプ	Oil pipe	1
K443		MG91103045	ナット	Nut 11/64(40)	1
K444		MG42A1689	パイプホルダ	Pipe holder	1
K445		MG91111004	パイプネジ	Screw 11/64(40)x10	1
K446		MG42B0400	ヒモ	Oil wick	3
K447		MG33A0688	パイプ	Oil pipe	1
K448		MG50A2740	フェルト	Felt	1
K449		MG43A0689	パイプホルダ	Pipe holder	1
K450		MG42A2691	ガスケット	Gasket for oil reservoir	1
K451		MG50A0139	パイプキャップ	Oil reservoir cover	1
K452		MG50A0257	プレート	Plate	1
K918		MG33E0711	アームシャフト	Arm shaft bevel gear box complete	1
K919		MG33E0712	フックシャフト	Hook shaft bevel gear box complete	1

L 付属品関係
 ACCESSORIES

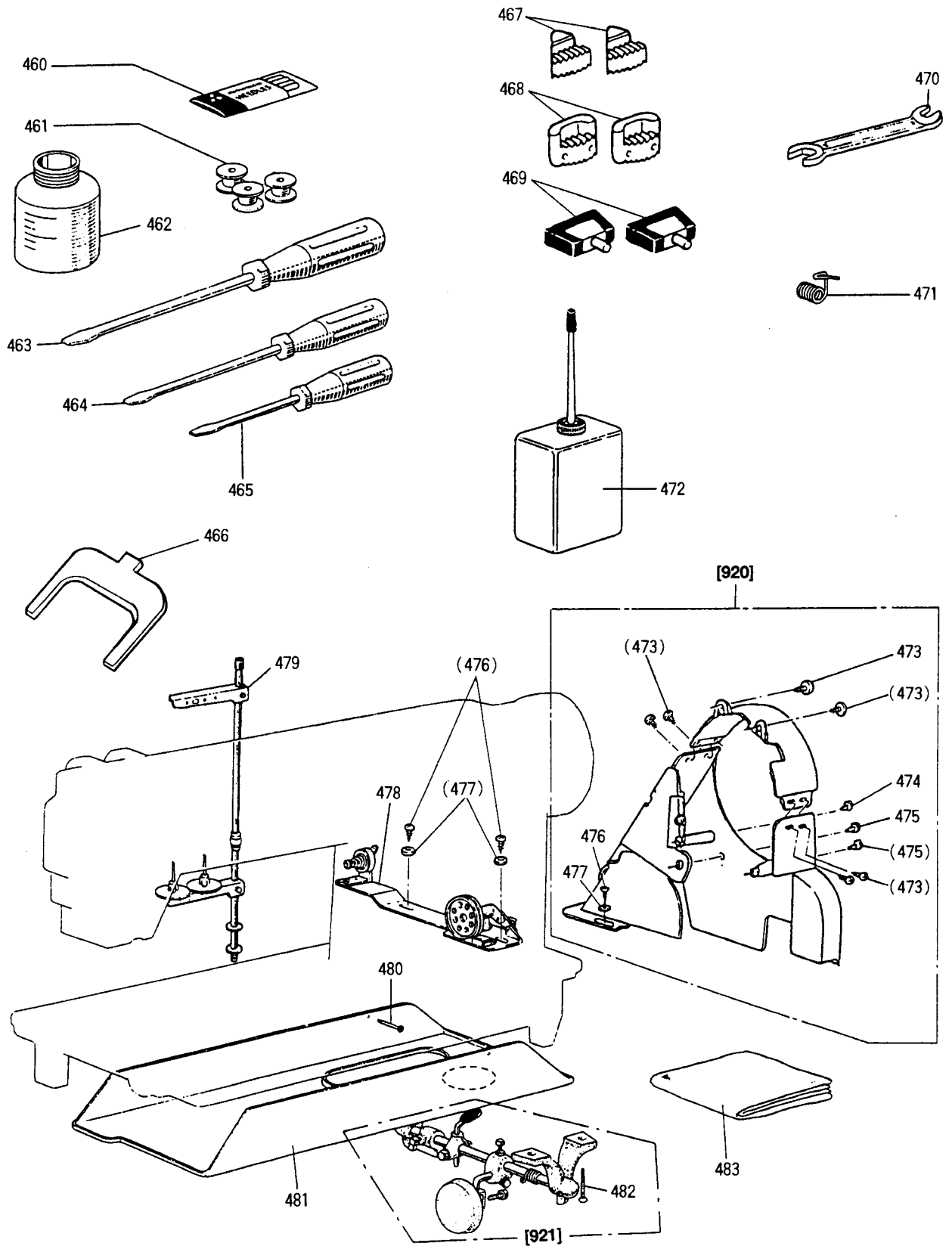

L 付属品関係
ACCESSORIES

Fig. 変更	部品コード	部品名	Description	使用数
No.	Mod	Parts.No.		Amt. Reg.
				BIT
L460		MG33E0128	ハリセット..... Needle set(DPX17#22).....	1
L461		MF25B0123	ホビーン..... Bobbin.....	3
L462		MG33A0130	アフラビン..... Oil pot.....	1
L463		MG33A0608	ドライバ-(タイ)..... Screw driver(large).....	1
L464		MF06A0608	ドライバ-(チユ)..... Screw driver(middle).....	1
L465		MF06A1608	ドライバ-(シヨウ)..... Screw driver(small).....	1
L466		MF01A0565	カクテチヨウセイク..... Speed command disc adjusting plate.....	1
L467		MG51A1419	ホウシンゴム..... Vibration preventing rubber.....	2
L468		MG51A0419	ホウシンゴム..... Vibration preventing rubber.....	2
L469		MF01E0418	チヨウハンセット..... Table hinge with rubber cushion.....	2
L470		MG33A0479	スパナ マルカタ..... Spanner.....	1
L471		MF02A0187	イトトリハネ..... Thread take-up spring.....	1
L472		MG33A0137	アフラシ 18..... Oil with oiler.....	1
L473		M91109004	サカネツキフライネジ..... Screw 11/64(40)x8.....	6
L474		M91072004	SW-PWツキPナネジ..... Screw SW-PW M4X0.7X14.....	1
L475		M91508004	フライネジ..... Screw 15/64(28)x8.....	2
L476		M90401041	マルモクネジ..... Screw 4.5x20.....	4
L477		M70517050	ミカキサカネ..... Washer 5.....	4
L478		MN69E0190	イトマキシカケ..... Bobbin winder assy.....	1
L479		MF33E0193	イトタテアイセット..... Thread stand assy.....	1
L480		MQ80A0375	クキ N25..... Nail N25.....	10
L481		MG52E0131	アフラウケクミタテ..... Oil reservoir assy.....	1
L482		M90404041	サラモクネジ 4.5X25..... Screw 4.5x25.....	4
L483		MG33A0734	ビニールカバー..... Vinyl cover.....	1
L920		MG33E0776	ベルトカバー-セット..... Belt cover assy.....	1
L921		MG33E0727	ヒザアケシカセット..... Knee lifter assy.....	1