

MITSUBISHI

三菱工業用ミシン部品カタログ

Industrial Sewing Machine Parts Catalog

Model LS2-1150

目次	INDEX	Page
Ⓐ 本体関係	Arm bed & it's accessories	2
Ⓑ 縫い機構	(I) Sewing mechanism (I)	4
Ⓒ 縫い機構	(II) Sewing mechanism (II)	6
Ⓓ 送り機構	Feed mechanism	8
Ⓔ 押え機構	Presser foot mechanism	10
Ⓕ 給油機構	Oil lubrication mechanism	12
Ⓖ 付属品	Accessories	14
Ⓗ 索引	Index	16

ミシン用部品コード採番基準

MITSUBISHI SPARE PARTS No. Designation system

注：※欄には英文字(A,B,...X,Y,Z)が入る。
Remarks : Alphabet(A,B,...X,Y,Z) should be taken at
※ mark.

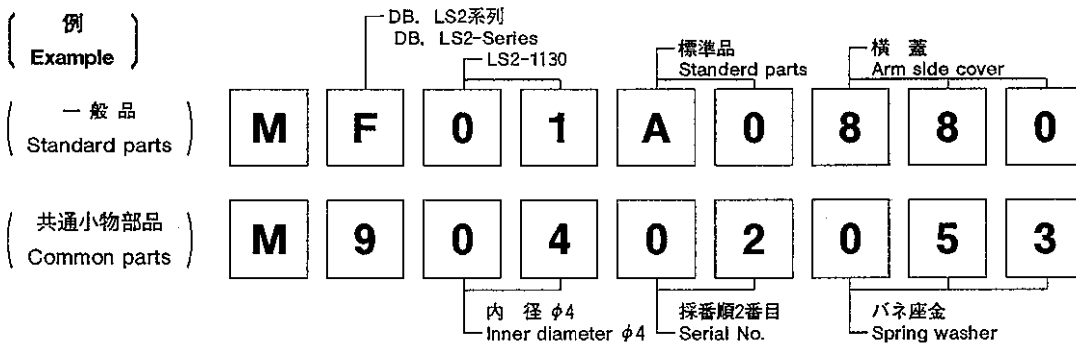
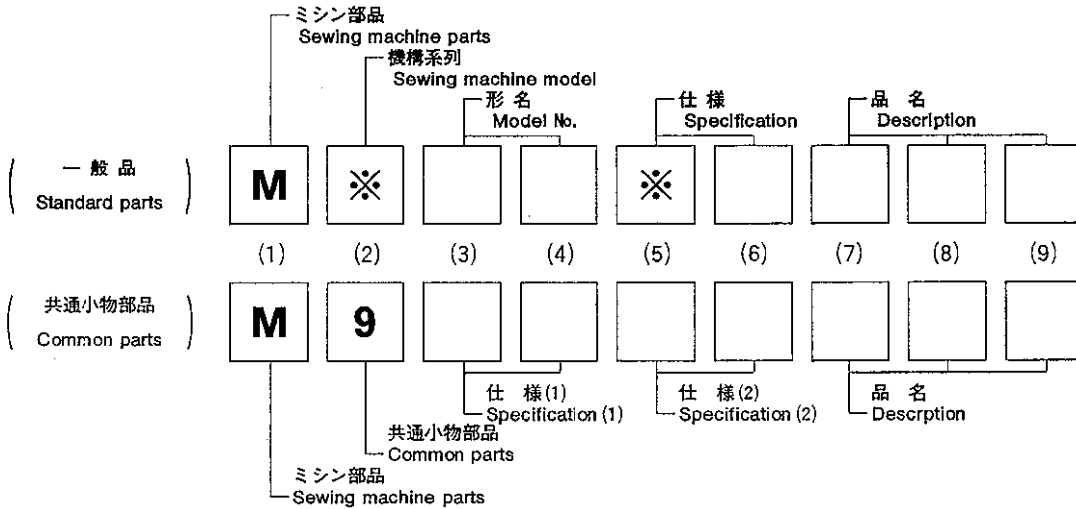

注：一般品についての機種形名は、その部品が最初に使用された機種形名を示します。従って長期に亘る場合は、機種の変更が行われるため、当初の機種以外の機種で使用されている場合があります。
Sewing machine Models, of Standard Parts are indicated model of these parts are registered firstly. Parts are used for not only the indicated model, but also another models, in reason of New development, Improvement after.

パーツカタログご利用に際して Information on use of the parts catalog

- 補用部品ご注文の際は、部品コードでご注文下さい。また、このパーツブックの管理番号と発行年月(表紙右下、例えば、P-187A 199510)モデル機械番号を、合わせてご連絡頂ければ幸いです。
 - 一部の部品について、改良のため予告なしに変更になる場合がありますのでご了承下さい。
 - このパーツカタログは1995年10月のデータにもとづいて作成されたものです。
 - 部品コード欄が、——となっている部品は、補給いたしません。ただし組コードが記載されているものは、組部品として補給いたしますので、組コードでご注文下さい。
 - 使用個数欄の英数字組合せ文字は、このモデル番号のサブ機械番号をしめています。
 - 尚、本パーツブックの記載内容にお気付きの点がありましたら、お知らせ頂ければ幸いです。
- When ordering any spare part, please specify its part code. In addition, please specify the management number and issued date of this parts catalog (e. g. P-187A 199510 indicated at bottom right of the front cover) and the machine model number.
 - Some parts are subject to change due to modification without notice.
 - This parts catalog is based the data as of Oct. 1995.
 - Any part marked - in the part code column will not be supplied. When a part has its assembly code, please specify the assembly code because that part is supplied as an assembly part.
 - Alphanumerical characters indicated in the required quantity column indicate the sub machine number of this model number.
 - Please write to us if you have any question on this parts catalog.

A 本体関係
 ARM BED & IT'S ACCESSORIES

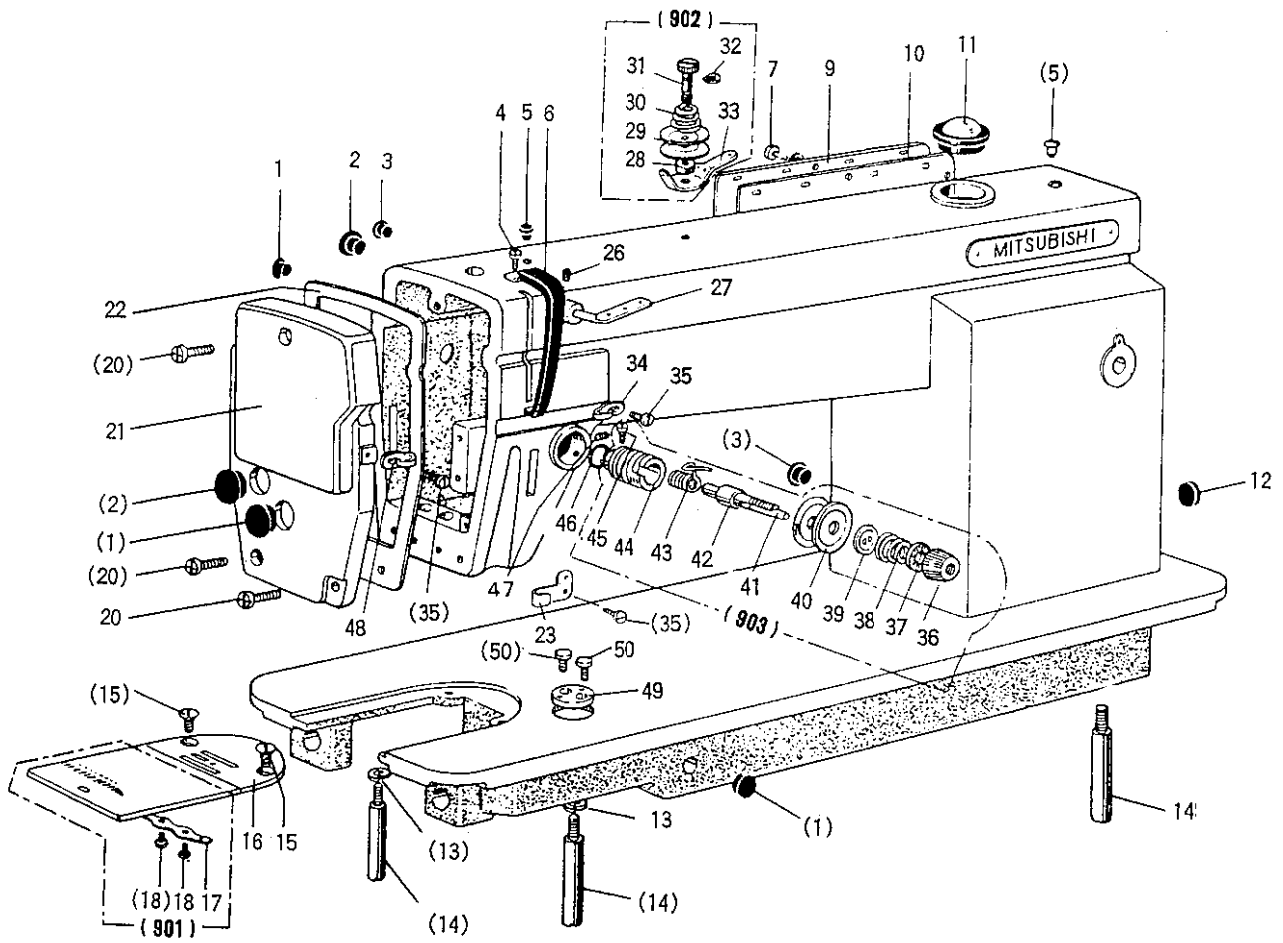

A 本体関係

ARM BED & IT'S ACCESSORIES

Fig. No.	変更 No.	部品コード Parts No.	部品名	Description	使用個数 Amt. Reg.
A1		M91182080	ゴムセシ	Rubber plug (φ11.8)	3
A2		M91900080	ゴムセシ	Rubber plug (φ19.0)	2
A3		M90883080	ゴムセシ	Rubber plug (φ8.8)	2
A4		M91116004	ブラマイネジ	Screw 11/64 (40) X8	1
A5		M90573080	ゴムセシ	Rubber plug (φ5.7)	2
A6		MN36A0584	テンビンカバー	Thread take-up cover	1
A7		M91109004	ザガネツキブラマイネジ	Screw 11/64 (40) X8	8
A9		MF30A0880	ヨコブタ	Arm side cover	1
A10		MF05A0691	ガスケット	Gasket	1
A11		MF20A0135	アブラマド	Oil check window	1
A12		M92701080	ゴムセシ	Rubber plug (φ27.0)	1
A13		M90625053	バネザガネ	Spring washer for leg 6	2
A14		MF30A0426	ササエ	Leg	3
A15		M91106011	マルサネジ	Screw 11/64 (40) X8	2
A16		MF11D0101	ハリイタ	Needle plate (B1.6)	1
A17		MF10A0471	イタバネ	Spring for slide plate	1
A18		M90613002	ヒラネジ	Screw 3/32 (56) X2.2	2
A20		M91117004	ブラマイネジ	Screw 11/64 (40) X10	3
A21		MF01A0830	メンイタ	Face plate	1
A22		MF01A1691	ガスケット	Gasket for face plate	1
A23		MQ50A0181	イトアンナイ	Thread guide	1
A26		M91108001	トメネジ	Set screw 11/64 (40) X5.5	1
A27		MF10A0180	イトアンナイ	Three hole thread guide	1
A28		MF30A0476	スペーサ	Spacer for pre-tension	1
A29		MF10A1555	チヨウシザラ	Tension discs for pre-tension	2
A30		MF20A0245	エンスイバネ	Tension spring for pre-tension	1
A31		M91104016	マルヒラネジ タンヅキ	Screw type tension stud 11/64 (40) X16	1
A32		M90512065	Eタイプメ	E-type stop ring 3	1
A33		MF70A0180	イトアンナイ	Thread guide for pre-tension	1
A34		MF80A0181	イトアンナイ	Thread guide	1
A35		M90909003	マルヒラネジ	Screw 9/64 (40) X6	3
A36		M91605045	ツマミネジ	Thumb nut	1
A37		MT60A0802	マワリドメ	Thumb net revolution stopper	1
A38		MN10A3245	エンスイバネ	Thread tension spring	1
A39		MM11A0556	チヨウシザラオサエ	Thread tension releasing discs	1
A40		MF10A0555	チヨウシザラ	Thread tension discs	2
A41		M90204060	ピン	Thread tension releasing pin	1
A42		MF10A0553	チヨウシホウ	Thread tension stud	1
A43		MF10A0187	イトリバネ	Thread take-up spring	1
A44		MF10A0709	ブツユ	Thread tension regulating bushing	1
A45		M90901002	ヒラネジ	Screw 9/64 (40) X4	1
A46		M91501085	O リンク NOK S15	Rubber ring NOK S15	1
A47		M91508001	トメネジ	Set screw 15/64 (28) X6	1
A48		MF10A0181	イトアンナイ	Thread guide	1
A49		MF01A0601	トリツカイタ	Plate for guide	1
A50		M91107002	ヒラネジ	Screw 11/64 (40) X5.5	2
A901		MF30E0470	スベリイタカタテ	Slide plate complete	1
A902		MF70E0550	チヨウセツキカタテ	Pre-Tension complete	1
A903		MF30E0210	チヨウセツキカタテ	Thread tension regulator complete	1

B 縫い機構(I)
 SEWING MECHANISM (I)

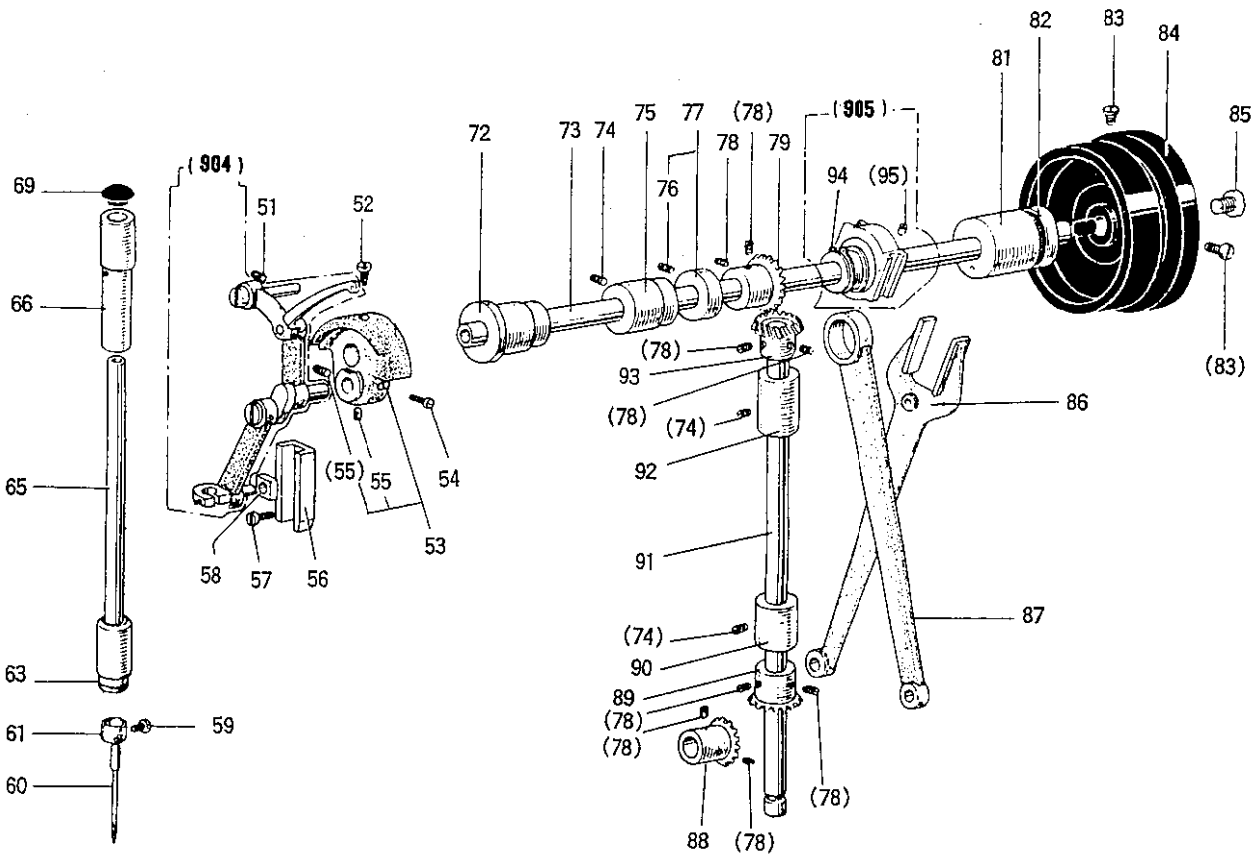

B 縫い機構 (I)

SEWING MECHANISM (I)

Fig. No.	変更 No.	部品コード Parts.No.	部品名	Description	使用個数 Amt. Reg.
B51		M91513001	トメネジ	Set screw 15/64 (28) X10	1
B52		M91802006	ヒラネジ ホウサキ	Screw 9/32 (28) X14	1
B53		MF90A0383	クランクミタテ	Crank	1
B54		M91801002	ヒラネジ	Set screw 9/32 (28) X13	1
B55		M91606001	トメネジ	Set screw 1/4 (40) X6	2
B56		MF80A0662	アノイダ イ	Needlebar connecting link guide	1
B57		M91110002	ヒラネジ	Screw 11/64 (40) X8	2
B58		MF30A0325	カクコマ	Square block	1
B59		M90815002	ヒラネジ	Screw 1/8 (44) X4.5	1
B60		MF70A0128	ミシンハリ DBX1-14	Needle set DBX1 #14	1
B61		MF05A0181	イトアンナイ	Thread guide	1
B63		MF10A0664	ハリホ ウメタルシク	Needle bar bushing (lower)	1
B65		MF30A0660	ハリホ ウクミタテ	Needle bar	1
B66		MF70A0663	ハリホ ウメタルウエ	Needle bar bushing (upper)	1
B69		M90884080	ゴムセン	Rubber plug (φ8.8)	1
B72		MF80A0232	ウウジ クメタルヒガリ	Bushing for arm shaft (left)	1
B73		MF85A0230	ウウジ ククミタテ (ゴムセンツキ)	Arm shaft	1
B74		M91513001	トメネジ	Set screw 15/64 (28) X10	3
B75		MF05A0234	ウウジ クメタルカ	Bushing for arm shaft (middle)	1
B76		M91602001	トメネジ	Set screw 1/4 (40) X4	2
B77		MF80A0352	カラークミタテ	Collar	1
B78		M91632001	トメネジ	Set screw 1/4 (40) X7	8
B79		MF40A0331	ウウジ クカサハク ルマ	Bevel gear for arm shaft	1
B81		MF01A0233	ウウジ クメタルミキ	Bushing for arm shaft (right)	1
B82		M91472086	オイルシール 91A-1192-R	Oil seal for arm shaft (right)	1
B83		M91502002	ヒラネジ	Set screw 15/64 (28) X12	2
B84		MF30A0682	プーリー	Pulley	1
B85		M92201003	マルヒラネジ	Screw 11/32 (28) X10	1
B86		MF30A0744	フタマダロツト	Feed forked connecting rod	1
B87		MF70A0384	レンゼツカン	Crank rod	1
B88		MF10A0332	シタジ クカサハク ルマ	Bevel gear for hook shaft	1
B89		MF10A0334	タテジ クカサハク ルマシタ	Bevel gear for vertical shaft (lower)	1
B90		MF70A0522	タテジ クメタルシク	Bushing for vertical shaft (lower)	1
B91		MF30A0520	タテジ ク	Vertical shaft	1
B92		MF00A0521	タテジ クメタルウエ	Bushing for vertical shaft (upper)	1
B93		MF40A0333	タテジ クカサハク ルマウエ	Bevel gear for vertical shaft (upper)	1
B94		M90320065	C カ タトメワ ジ クヨウ 20	C-type stop ling 20	1
B95		M91506001	トメネジ	Set screw 15/64 (28) X7	2
B904		MF05E0580	テンビ ンハリククミタテ	Thread take-up lever complete	1
B905		MF30E0280	ヘンシンリンクミタテ	Feed cam complete	1

㊦ 縫い機構(Ⅱ)
SEWING MECHANISM (Ⅱ)

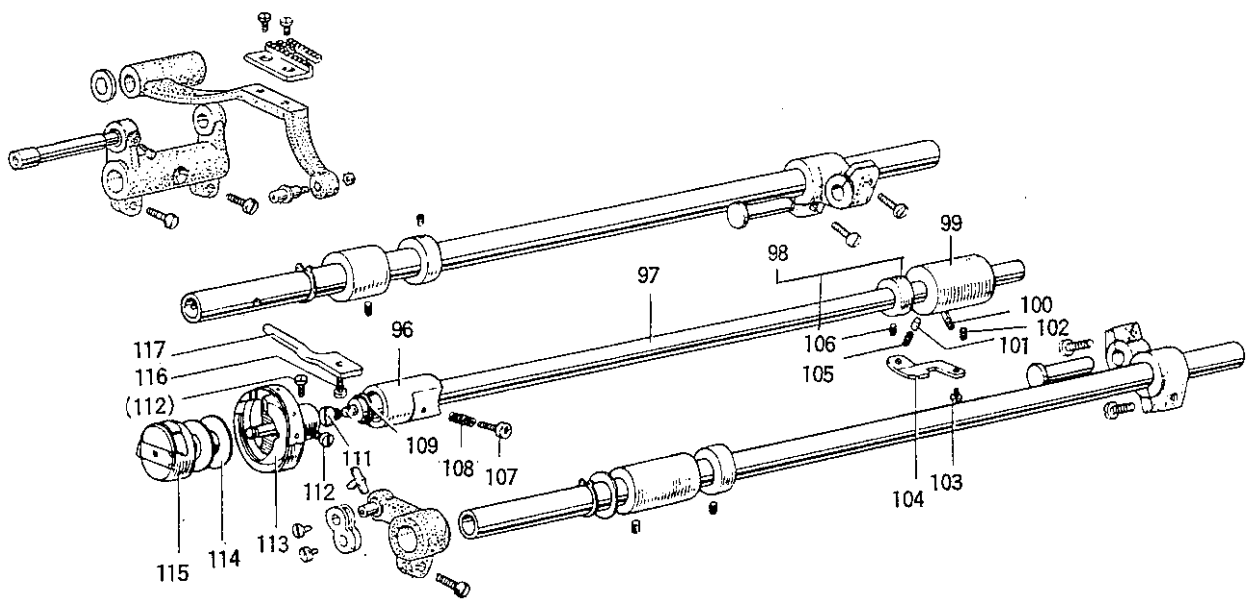

㊦ 縫い機構(Ⅱ)

SEWING MECHANISM (Ⅱ)

Fig. No.	変更 No. Mod.	部品コード Parts No.	部品名	Description	使用個数 Ant. Reg.
C96		MF80A0451	シタジ ^ク メタルヒタ ^リ	Bushing for hook shaft(left)	1
C97		MF30A0450	シタジ ^ク	Rotating hook shaft	1
C98		MF30A0352	カラ ^ク ミタ ^テ	Collar	1
C99		MF00A0452	シタジ ^ク メタルミキ	Bushing for hook shaft(right)	1
C100		MF80A0688	パイ ^プ	Pipe	1
C101		MF00A0753	プ ^ラ ン ^ジ ヤ ^ー	Plunger	1
C102		M91513001	トメネジ	Set screw 15/64(28)X10	1
C103		M91515002	ヒラネジ	Screw 15/64(28)X10	1
C104		MF30A0154	ア ^ン ナ ^イ タ	Guide plate	1
C105		MF00A0572	ツルマキハ ^ネ	Spring	1
C106		M91503001	トメネジ	Set screw 15/64(28)X4.5	2
C107		M97084030	トクシユネジ	Oil adjusting screw	1
C108		MF80A1572	ツルマキハ ^ネ	Spring	1
C109		M90803086	オイルシール	Oil seal	1
C111		M91259030	トクシユネジ ^フ エル ^ト クミタ ^テ	Special screw	1
C112		M91101002	ヒラネジ	Set screw 11/64(40)X4	2
C113		MF16A0120	カマクミタ ^テ	Rotating hook	1
C114		MF10A0123	ホ ^ビ ン	Bobbin	1
C115		MF30A0125	ホ ^ビ ンケ ^ー ス	Bobbin case	1
C116		M91118002	ヒラネジ	Screw 11/64(40)X10	1
C117		MF30A0229	ウチガ ^マ ト ^メ	Rotating hook positioner	1

□ 送り機構
FEED MECHANISM

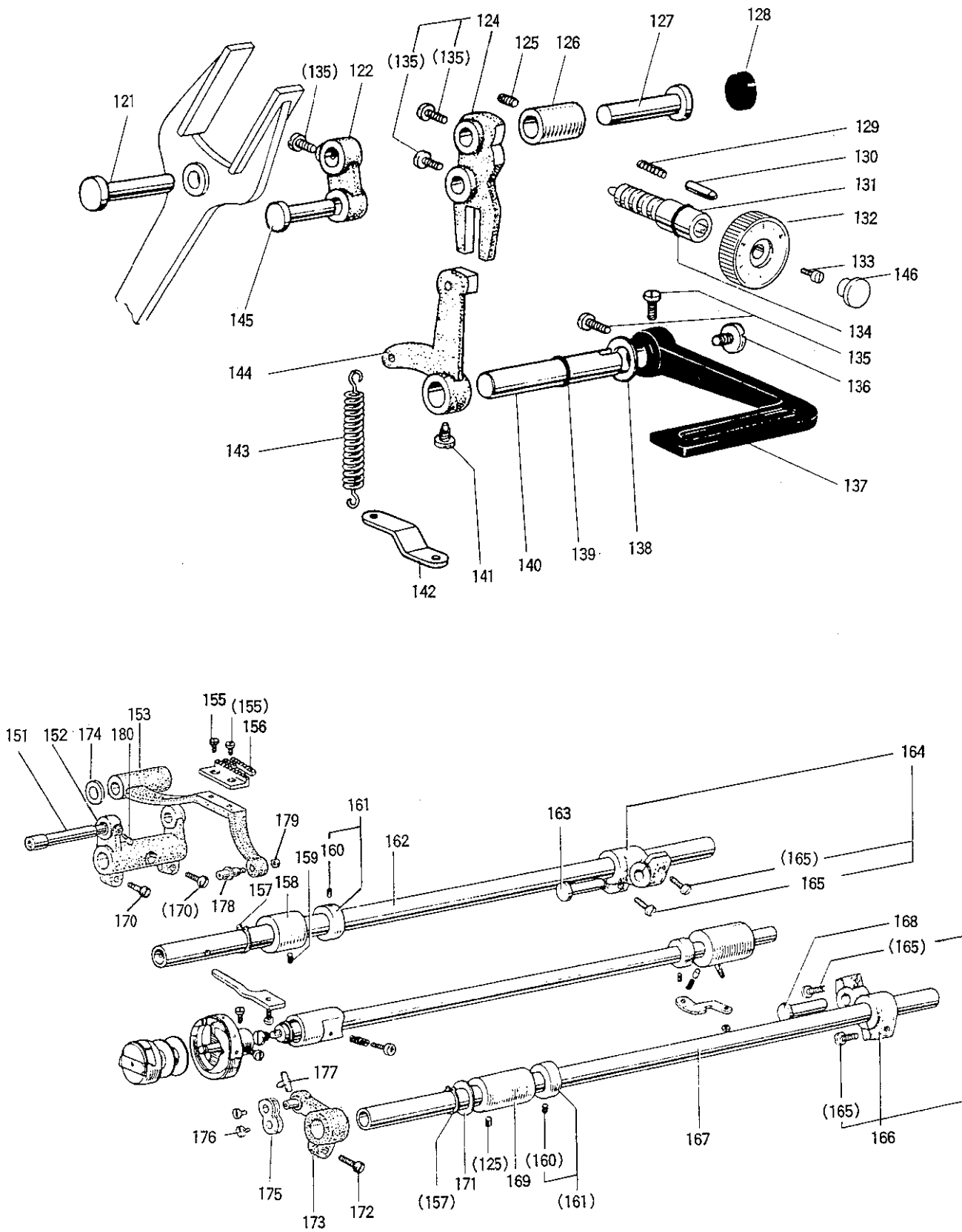

□ 送り機構

FEED MECHANISM

Fig. 変更 No. Mod.	部品コード Parts.No.	部品名	Description	使用個数 Amt. Reg.
D121	M90718063	ダ`ンツキジ`ク	Set pin	1
D122	MF70A0153	レンセツカン	Feed connecting link	1
D124	MF80A0152	オカリチヨウセツカム	Feed regulator	1
D125	M91513001	トメネジ	Set screw 15/64 (28)X10	2
D126	MF10A0750	ブ`ツシュ	Bushing for feed regulator	1
D127	MF30A0530	ダ`ンツキジ`ク	Set pin	1
D128	M92006080	ゴ`ムセ`ン	Rubber plug(φ20)	1
D129	MF05A0572	ツルマキハ`ネ	Spring	1
D130	MF30A0852	ピン	Stopper pin for stitch length regulator	1
D131	MF60A1640	オカリチヨウセツネジ	Screw bar	1
D132	MF05A2631	ダイヤル	Dial for stitch length regulator (0-5)	1
D133	M91209002	ヒラネジ	Screw 3/16 (28) X8	1
D134	M91000085	0 リンク` 1AP10A	0-ring (φ10) (1AP10A)	1
D135	M91515002	ヒラネジ	Screw 15/64 (28) X10	6
D136	M91207003	マルヒラネジ	Screw 3/16 (28) X6.5	1
D137	MF30A0632	ヌイメカケ`ンレハ`	Reverse sewing lever	1
D138	M95003053	ハ`ネサ`カ`ネ	Spring washer M10	1
D139	M90600085	0 リンク` 1AP6	0-ring (φ6) (1AP6)	1
D140	MF10A0633	ヌイメカケ`ンツ`ク	Shaft for reverse sewing lever	1
D141	M91501007	マルヒラネジ` ホ`ウサキ	Screw 15/64 (28) X14.5	1
D142	MF30A0708	カケガ`ネ	Bracket for spring	1
D143	MF10A0572	ツルマキハ`ネ	Spring	1
D144	MF40E1635	ヌイメカケ`ンウテ`クミタテ	Reverse sewing crank complete	1
D145	M90905063	ダ`ンツキヒ`ン	Set pin for feed connecting link	1
D146	M91184080	ゴ`ムセ`ン	Rubber plug (φ10.8)	1
D151	MF33A0283	ダ`ンツキジ`ク	Set pin	1
D152	MF90A0278	スイ`ヘイ`オクリウテ`ヒタ`リ	Feed rock shaft crank (left)	1
D153	MF05A1281	オクリダ`イ	Feed bar	1
D155	M90806002	ヒラネジ	Screw 1/8 (44) X6	2
D156	MF10A0104	オクリ	Feed dog	1
D157	M90315065	Cガ`タトメウ`ジ`クヨウ` 15	C-type stop ring 15	2
D158	MF70A1286	オクリジ`クメタル	Bushing for feed rock shaft (left)	1
D159	M91503001	トメネジ	Set screw 15/64 (28) X4.5	1
D160	M91602001	トメネジ	Set screw 1/4 (40) X4	4
D161	MF80A0352	カテ`クミタテ	Collar	2
D162	MF70A0491	スイ`ヘイ`オクリジ`ク	Feed rock shaft	1
D163	M90904060	ピン	Pin	1
D164	MF70A0279	スイ`ヘイ`オクリウテ`ミキ`	Feed rock shaft crank (right)	1
D165	M91204003	マルヒラネジ	Screw 3/16 (28) X12	4
D166	MF70A0277	ジ`ヨウゲ`オクリウテ`ミキ`	Feed lifting rock shaft crank (right)	1
D167	MF30A0460	ジ`ヨウゲ`オクリジ`ク	Feed lifting rock shaft	1
D168	M90904060	ピン	Pin	1
D169	MF70A0286	オクリジ`クメタル	Bushing for food lifting rock shaft (left)	1
D170	M91204003	マルヒラネジ	Screw 3/16 (28) X12	2
D171	M91502050	サ`ガ`ネ	Washer	1
D172	M91112002	ヒラネジ	Screw 11/64 (40) X12	1
D173	MF05A1276	ジ`ヨウゲ`オクリウテ`ヒタ`リクミタテ	Crank complete for feed lifting rock shaft	1
D174	M90619050	サ`ガ`ネ	Washer	1
D175	MF05A0910	リンク	Link	1
D176	M90942003	マルヒラネジ	Screw 9/64 (40) X6.5	2
D177	MF05A0780	ホルダ`	Holder	1
D178	M91257030	トクシユネジ	Screw	1
D179	M91252045	ナツト	Nut 3/16 (32) X3.5	1
D180	M91110002	ヒラネジ	Screw 11/64 (40) X8	1

□ 押え機構
PRESSER FOOT MECHANISM

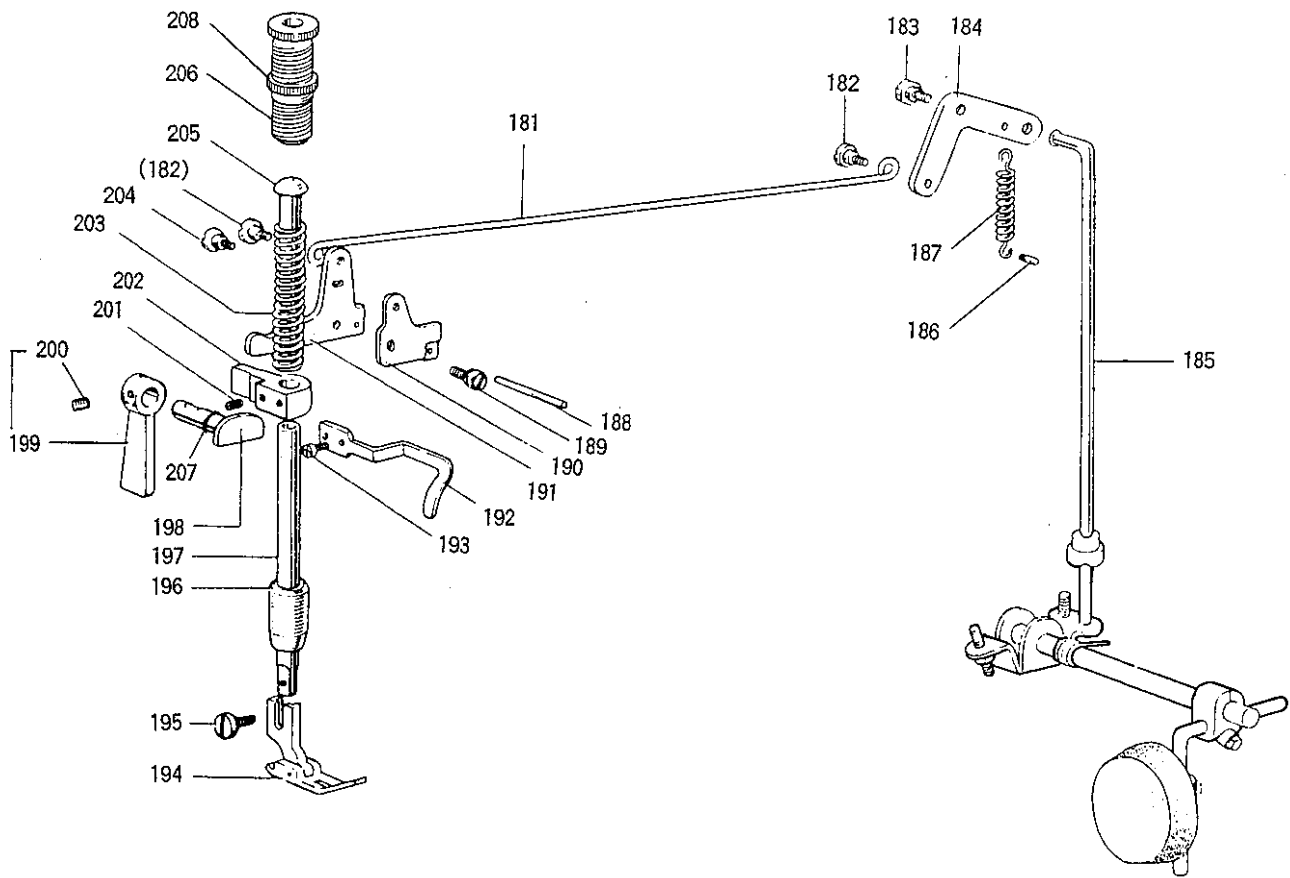

□ 押え機構

PRESSER FOOT MECHANISM

Fig. 変更 部品コード		部品名	Description	使用個数
No. Mod.	Parts.No.			Amt. Reg.
E181	MF30A0738	ヒキ棒ウ	Knee liffter rod	1
E182	M91219015	ヒラネジ ダンツキ	Hinged screw 3/16(28)X7	2
E183	M91503031	ボルト	Bolt for knee lifter lever	1
E184	MF30A0252	オサエアゲレハミキ	Knee lifter lever(right)	1
E185	MF70A0511	ソウサネウ	Knee lifter connecting rod	1
E186	M95003067	ミゾツキピン BX カタ 5X24	Pin(BX-Type) (φ5X24)	1
E187	MF30A0572	ツルマキハネ	Spring for knee lifter lever	1
E188	M90419060	イトルメピン	Tension releasing pin(φ4X37.5)	1
E189	M91515022	ボルト	Bolt 15/64(28)X13.5	1
E190	MF70A0350	イトルメカム	Tension releasing cam	1
E191	MF70A2950	オサエアゲレハミキ	Knee lifter lever(left)	1
E192	MN30A0216	ウイトアンナイ	Thread guide	1
E193	M91116004	ブラマイネジ	Screw 11/64(40)X8	1
E194	MF10A0105	オサエクミタテ	Presser foot	1
E195	M90939002	ヒラネジ	Screw 9/64(40)X11	1
E196	MF10A0267	オサエネウメタル	Bushing for presser bar	1
E197	MF11D0262	オサエネウ	Presser bar	1
E198	MF30A0253	オサエアゲカム	Presser bar lifting cam	1
E199	MF00A0252	オサエアゲ	Presser bar lifter	1
E200	M91108001	トメネジ	Set screw 11/64(40)X5.5	1
E201	M91506001	トメネジ	Set screw 15/64(28)X7	1
E202	MF30A0265	オサエネウカタネ	Presser bar lifting bracket	1
E203	MF12B0259	ツルマキハネ	Presser spring	1
E204	M91131002	ヒラネジ	Screw 11/64(40)X6.5	1
E205	MF30A0703	アンナイネウ	Presser bar guide	1
E206	M93220035	ツマミネジ	Thumb screw 1/2(28)X63	1
E207	M90400085	O リンク 1AP4	O-ring(1AP4)	1
E208	M93202047	トクシユナツト	Nut	1

F 給油機構
LUBRICATION MECHANISM

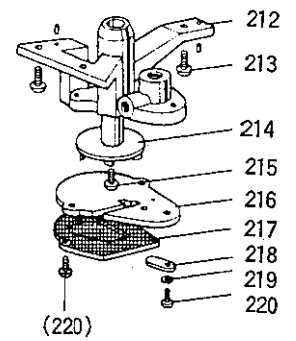
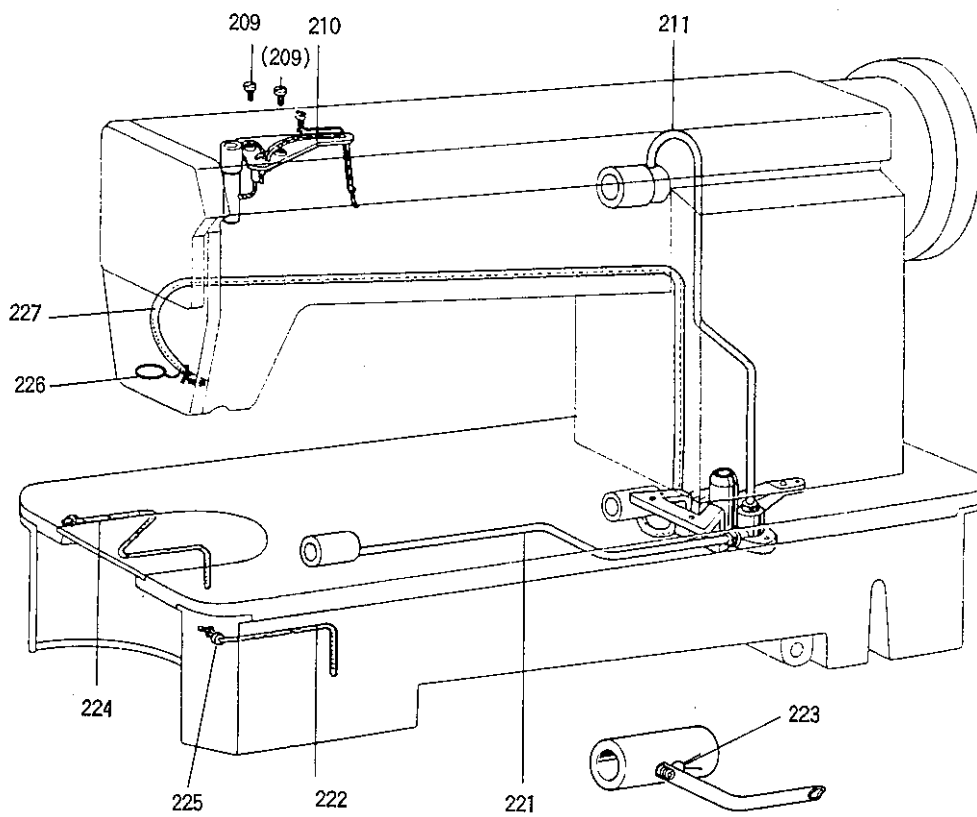

F 給油機構

LUBRICATION MECHANISM

Fig. No.	変更 No.	部品コード Parts.No.	部品名	Description	使用個数 Amt. Reg.
F209		M90939002	ヒラネジ	Screw 9/64(40)X11	2
F210		MF30E0601	トリツケイタヒモクミタテ	Oil braid fitting plate	1
F211		MF80A1688	パイプウエキミタテ	Oil pipe for arm shaft	1
F212		MF80A0783	ポンプケース	Oil pump	1
F213		M91135002	ヒラネジ	Screw 11/64(40)X13	3
F214		MF10A0685	ハネガムマ	Oil pump impeller	1
F215		M90810002	ヒラネジ	Screw 1/8(44)X6.5	1
F216		MF30A1601	トリツケイタ	Oil pump fitting plate	1
F217		MF30E0337	アミクミタテ	Oil pump screen	1
F218		MF30A0742	フタ	Oil adjusting plate	1
F219		M90307053	ハネガガネ	Spring washer M3.5	1
F220		M90820002	ブラマイネジ	Screw 1/8(44)X13	3
F221		MF30E0688	パイプシタクミタテ	Oil pipe for hook shaft	1
F222		MF10E2148	ヒモ	Oil braid(φ2.5X240)	1
F223		MF30A0378	タムマクリップ 6	Holder for oil braid 6	1
F224		MF10E2148	ヒモ	Oil braid(φ2.5X330)	1
F225		MF70A3731	パイプ	Pipe	1
F226		MF00A2780	ホルダ	Holder	1
F227		MF01E0731	パイプクミタテ	Oil return pipe	1

㊄ 付属品
ACCESSORIES

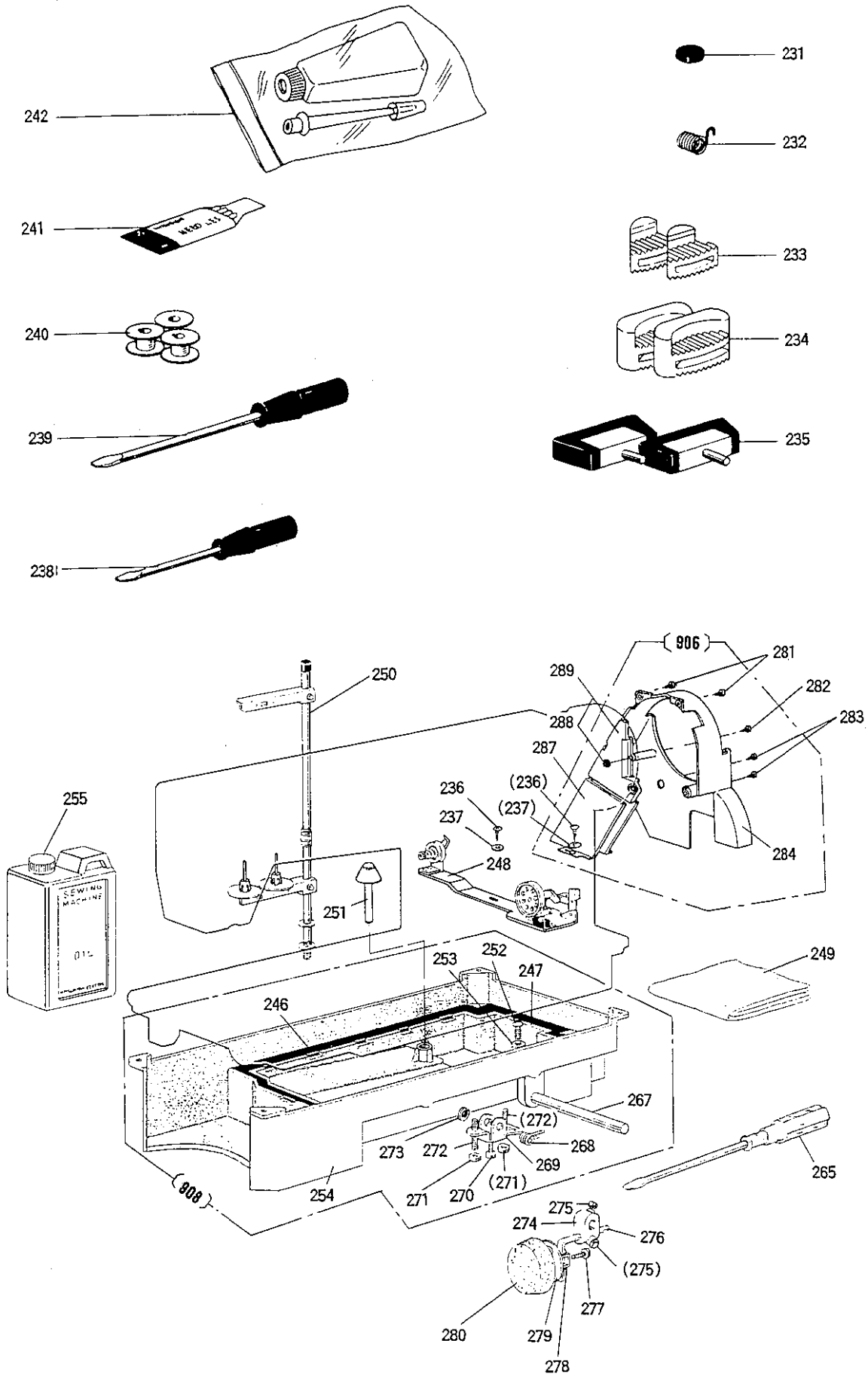

㊄ 付属品
ACCESSORIES

Fig. 変更 No. Mod.	部品コード Parts. No.	部品名	Description	使用個数 Amt. Reg.
G231	M90701099	OP-S ジンヤク	Magnet block for reservoir	1
G232	MF10A0187	イトリハネ	Thread take-up spring	1
G233	MF01A1419	ホウシゴム	Vibration preventing rubber	2
G234	MF01A0419	ホウシゴム	Vibration preventing rubber	2
G235	MF30E0418	チヨウバンセット	Table hinge with rubber cushion	2
G236	M90405041	マルモクネジ	Screw 4.1X20	4
G237	M90515050	ワッシャ	Washer M5	4
G238	MF33A0608	ネジマワシ(シヨウ)	Screw driver (small)	1
G239	MF33A1608	ネジマワシ(チュウ)	Screw driver (middle)	1
G240	MF10A0123	ボビン	Bobbin	3
G241	MF30E0128	ハリセット	Needle set DBX1 #14	1
G242	MF60A0137	アブラサシ	Oil with oiler	1
G246	MF20A3691	ガスケット	Gasket for oil reservoir (large)	1
G247	MF20A2691	ガスケット	Gasket for oil reservoir (small)	1
G248	MN70E0190	ボビンカケ	Bobbin winder complete	1
G249	MF33A0734	ビニールカバー	Vinyl cover	1
G250	MF33E0193	イトタテアイセット	Thread stand complete	1
G251	MF30A0578	ヒザアゲピン	Knee lifter lifting rod	1
G252	M92002002	ヒラネジ	Oil drain screw 5/16 (28)X10	1
G253	M97001052	トクシユサガネ	Washer	1
G254	MF30A0139	アブラサシ	Oil reservoir	1
G255	MF10E0149	アブラカン	Oil can	1
G265	MF00A0608	ネジマワシ(オウイ)	Screw driver (large)	1
G267	MF30A0723	ヒザアゲシャフト	Knee lifter shaft	1
G268	MF20A1729	ヒネリバネ	Knee lifter spring	1
G269	MF20A1724	ヒザアゲレバ	Knee lifter	1
G270	M91502002	ヒラネジ	Screw 15/64 (28)X12	1
G271	M91501045	ナット	Nut 15/64 (28)	2
G272	M91520001	トメネジ	Set screw 15/64 (28)X28	2
G273	M90521065	Eカクストメワ 9	E-type stop ling 9	1
G274	MF40A0784	ツギテ	Knee lifter coupling joint	1
G275	M92003031	トクシユボルト	Bolt 5/16 (18)X16	2
G276	MF20A0728	ソウサホウ	Knee lifter shaft	1
G277	M91510022	ボルト	Bolt 15/64 (28)X8	1
G278	MF30A0477	ストッパ	Knee lifter plate stopper	1
G279	MF40A0737	ヒザアゲプレート	Knee lifter plate	1
G280	MF40A1737	ヒザアゲカバー	Knee lifter cover	1
G281	M91109004	ワッシャ	Screw 11/64 (40)X8	2
G282	M91072004	SW-PWツギレバ	Screw M4X0.7X14	1
G283	M91509004	ワッシャ	Screw 15/64 (28)X8	2
G284	MF33A0776	ベルトカバー	Belt cover	1
G287	MF01A1776	ベルトカバー	Belt cover	1
G288	M91003045	ナット M4	Nut M4	1
G289	MF30A0776	ベルトカバー	Belt cover	1
G906	MF33E0776	ベルトカバーセット	Belt cover complete	1
G908	MF30E0139	アブラサシ	Oil reservoir complete	1

索引 INDEX

部品コード Parts. No.	ページ Page	Fig. No.	部品コード Parts. No.	ページ Page	Fig. No.	部品コード Parts. No.	ページ Page	Fig. No.	部品コード Parts. No.	ページ Page	Fig. No.
M90204060	P3	A41	M91501085	P3	A46	MF10A0105	P11	E194	MF30A1601	P13	F216
M90307053	P13	F219	M91502002	P5	B83	MF10A0123	P7	C114	MF30E0128	P15	G241
M90315065	P9	D157		P15	G270		P15	G240	MF30E0139	P15	G908
M90320065	P5	B94	M91502050	P9	D171	MF10A0180	P3	A27	MF30E0210	P3	A903
M90400085	P11	E207	M91503001	P7	C106	MF10A0181	P3	A48	MF30E0280	P5	B905
M90405041	P15	G236		P9	D159	MF10A0187	P3	A43	MF30E0337	P13	F217
M90419060	P11	E188	M91503031	P11	E183		P15	G232	MF30E0418	P15	G235
M90512065	P3	A32	M91506001	P5	B95	MF10A0267	P11	E196	MF30E0470	P3	A901
M90515050	P15	G237		P11	E201	MF10A0332	P5	B88	MF30E0601	P13	F210
M90521065	P15	G273	M91508001	P3	A47	MF10A0334	P5	B89	MF30E0688	P13	F221
M90573080	P3	A5	M91509004	P15	G283	MF10A0471	P3	A17	MF33A0283	P9	D151
M90600085	P9	D139	M91510022	P15	G277	MF10A0553	P3	A42	MF33A0608	P15	G238
M90613002	P3	A18	M91513001	P5	B51	MF10A0555	P3	A40	MF33A0734	P15	G249
M90619050	P9	D174		P5	B74	MF10A0572	P9	D143	MF33A0776	P15	G284
M90625053	P3	A13		P7	C102	MF10A0633	P9	D140	MF33A1608	P15	G239
M90701099	P15	G231		P9	D125	MF10A0664	P5	B63	MF33E0193	P15	G250
M90718063	P9	D121	M91515002	P7	C103	MF10A0685	P13	F214	MF33E0776	P15	G906
M90803086	P7	C109		P9	D135	MF10A0709	P3	A44	MF40A0331	P5	B79
M90806002	P9	D155	M91515022	P11	E189	MF10A0750	P9	D126	MF40A0333	P5	B93
M90810002	P13	F215	M91520001	P15	G272	MF10A1555	P3	A29	MF40A0737	P15	G279
M90815002	P5	B59	M91602001	P5	B76	MF10E0149	P15	G255	MF40A0784	P15	G274
M90820002	P13	F220		P9	D160	MF10E2148	P13	F222	MF40A1737	P15	G280
M90883080	P3	A3	M91605045	P3	A36		P13	F224	MF40E1635	P9	D144
M90884080	P5	B69	M91606001	P5	B55	MF11D0101	P3	A16	MF60A0137	P15	G242
M90901002	P3	A45	M91632001	P5	B78	MF11D0262	P11	E197	MF60A1640	P9	D131
M90904060	P9	D163	M91801002	P5	B54	MF12B0259	P11	E203	MF70A0128	P5	B60
	P9	D168	M91802006	P5	B52	MF16A0120	P7	C113	MF70A0153	P9	D122
M90905063	P9	D145	M91900080	P3	A2	MF20A0135	P3	A11	MF70A0180	P3	A33
M90909003	P3	A35	M92002002	P15	G252	MF20A0245	P3	A30	MF70A0277	P9	D166
M90939002	P11	E195	M92003031	P15	G275	MF20A0728	P15	G276	MF70A0279	P9	D164
	P13	F209	M92006080	P9	D128	MF20A1724	P15	G269	MF70A0286	P9	D169
M90942003	P9	D176	M92201003	P5	B85	MF20A1729	P15	G268	MF70A0350	P11	E190
M91000085	P9	D134	M92701080	P3	A12	MF20A2691	P15	G247	MF70A0384	P5	B87
M91003045	P15	G288	M93202047	P11	E208	MF20A3691	P15	G246	MF70A0491	P9	D162
M91072004	P15	G282	M93220035	P11	E206	MF30A0125	P7	C115	MF70A0511	P11	E185
M91101002	P7	C112	M95003053	P9	D138	MF30A0139	P15	G254	MF70A0522	P5	B90
M91104016	P3	A31	M95003067	P11	E186	MF30A0154	P7	C104	MF70A0663	P5	B66
M91106011	P3	A15	M97001052	P15	G253	MF30A0229	P7	C117	MF70A1286	P9	D158
M91107002	P3	A50	M97084030	P7	C107	MF30A0252	P11	E184	MF70A2950	P11	E191
M91108001	P3	A26	MF00A0252	P11	E199	MF30A0253	P11	E198	MF70A3731	P13	F225
	P11	E200	MF00A0452	P7	C99	MF30A0265	P11	E202	MF70E0550	P3	A902
M91109004	P3	A7	MF00A0521	P5	B92	MF30A0325	P5	B58	MF80A0152	P9	D124
	P15	G281	MF00A0572	P7	C105	MF30A0352	P7	C98	MF80A0181	P3	A34
M91110002	P5	B57	MF00A0608	P15	G265	MF30A0378	P13	F223	MF80A0232	P5	B72
	P9	D180	MF00A0753	P7	C101	MF30A0426	P3	A14	MF80A0352	P5	B77
M91112002	P9	D172	MF00A0780	P13	F226	MF30A0450	P7	C97		P9	D161
M91116004	P3	A4	MF01A0233	P5	B81	MF30A0460	P9	D167	MF80A0451	P7	C96
	P11	E193	MF01A0419	P15	G234	MF30A0476	P3	A28	MF80A0662	P5	B56
M91117004	P3	A20	MF01A0601	P3	A49	MF30A0477	P15	G278	MF80A0688	P7	C100
M91118002	P7	C116	MF01A0830	P3	A21	MF30A0520	P5	B91	MF80A0783	P13	F212
M91131002	P11	E204	MF01A1419	P15	G233	MF30A0530	P9	D127	MF80A1572	P7	C108
M91135002	P13	F213	MF01A1691	P3	A22	MF30A0572	P11	E187	MF80A1688	P13	F211
M91182080	P3	A1	MF01A1776	P15	G287	MF30A0578	P15	G251	MF85A0230	P5	B73
M91184080	P9	D146	MF01E0731	P13	F227	MF30A0632	P9	D137	MF90A0278	P9	D152
M91204003	P9	D165	MF05A0181	P5	B61	MF30A0660	P5	B65	MF90A0383	P5	B53
	P9	D170	MF05A0234	P5	B75	MF30A0682	P5	B84	MM11A0556	P3	A39
M91207003	P9	D136	MF05A0572	P9	D129	MF30A0703	P11	E205	MN10A3245	P3	A38
M91209002	P9	D133	MF05A0691	P3	A10	MF30A0708	P9	D142	MN30A0216	P11	E192
M91219015	P11	E182	MF05A0780	P9	D177	MF30A0723	P15	G267	MN36A0584	P3	A6
M91252045	P9	D179	MF05A0910	P9	D175	MF30A0738	P11	E181	MN70E0190	P15	G248
M91257030	P9	D178	MF05A1276	P9	D173	MF30A0742	P13	F218	MG50A0181	P3	A23
M91259030	P7	C111	MF05A1281	P9	D153	MF30A0744	P5	B86	MT60A0802	P3	A37
M91472086	P5	B82	MF05A2631	P9	D132	MF30A0776	P15	G289			
M91501007	P9	D141	MF05E0580	P5	B904	MF30A0852	P9	D130			
M91501045	P15	G271	MF10A0104	P9	D156	MF30A0880	P3	A9			

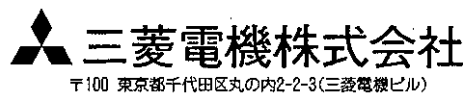

〒100 東京都千代田区丸の内2-2-3(三菱電機ビル)

-
- 本 社 〒100 東京都千代田区丸の内2-2-3(三菱電機ビル) 東京(03)3218-3522
 - 名古屋製作所 〒461 名古屋市東区矢田南5-1-14 名古屋(052)712-2208